

Beolab 90

Technical Sound Guide

Bang & Olufsen A/S
August 6, 2020

This manual is for information purposes only and is not legally binding.

Contents

| | |
|--|-----------|
| 1 Quick Setup Guide | 7 |
| 2 Introduction | 8 |
| 2.1 Features | 8 |
| 2.1.1 Beam Width Control | 9 |
| 2.1.2 Beam Direction Control | 9 |
| 2.1.3 ARC: Active Room Compensation | 10 |
| 2.1.4 Performance | 10 |
| 3 User Interface | 11 |
| 3.1 Daily use with the Bang & Olufsen app | 11 |
| 3.2 Navigation within the web interface | 13 |
| 3.3 Menu Map | 14 |
| 4 Presets | 15 |
| 4.1 What is a Preset? | 15 |
| 4.2 Preset management | 15 |
| 4.2.1 Selecting a Preset | 15 |
| 4.2.2 Creating and Editing a Preset | 15 |
| 4.2.3 Deleting a Preset | 15 |
| 5 Control Parameters | 16 |
| 5.1 Beam Width Control | 16 |
| 5.1.1 Narrow | 16 |
| 5.1.2 Wide | 17 |
| 5.1.3 Omni | 18 |
| 5.1.4 Comment | 19 |
| 5.2 Beam Direction Control | 19 |
| 5.3 Speaker Distance | 20 |
| 5.3.1 Adjusting Speaker Distances with a rotated Beam Direction | 20 |
| 5.3.2 Adjusting Speaker Distances for more than one listening position | 20 |
| 5.4 Speaker Level | 20 |
| 5.5 Speaker Role | 21 |
| 5.6 Active Room Compensation | 21 |
| 5.6.1 Creating a new ARC Zone | 21 |
| 5.6.2 Selecting an ARC Zone | 22 |
| 5.6.3 Combining ARC Zones | 22 |
| 5.7 Volume | 22 |
| 5.8 Mute | 22 |
| 5.9 Tone Controls | 22 |
| 5.9.1 Treble | 23 |
| 5.9.2 Bass | 23 |
| 5.10 Advanced Controls | 23 |
| 5.10.1 Latency Mode | 23 |
| 5.10.1.1 Auto | 23 |

| | |
|---|-----------|
| 5.10.1.2 High | 23 |
| 5.10.1.3 Low | 24 |
| 5.10.1.4 Effects of Latency Mode on Beam Width | 24 |
| 5.10.2 Parametric Equaliser | 24 |
| 5.10.2.1 Magnitude Response Plots | 24 |
| 5.11 Automating Preset Selection | 26 |
| 5.11.0.1 By Speaker Group | 26 |
| 5.11.0.2 By Source | 26 |
| 5.11.0.3 Mixed systems | 26 |
| 6 Inputs | 28 |
| 6.1 Inputs Selection | 28 |
| 6.1.1 Automatic Selection | 28 |
| 6.1.1.1 Selection Priority | 28 |
| 6.1.2 Manual Selection | 28 |
| 6.2 Individual Input Parameters | 28 |
| 6.2.1 Automatic Preset Selection | 28 |
| 6.2.2 Detection Threshold | 28 |
| 6.2.3 Maximum Input Voltage | 28 |
| 6.2.4 Time-out | 29 |
| 6.2.5 Input Impedance | 29 |
| 6.2.6 Control Presets using Speaker Groups | 29 |
| 6.3 Connection Panels | 29 |
| 7 System | 30 |
| 7.0.1 Max Volume | 30 |
| 7.0.2 Startup Volume | 30 |
| 8 Tables | 31 |
| 8.1 Loudspeaker Sensitivity | 31 |
| 8.2 Volume Control | 31 |
| 8.3 Parametric Equaliser | 31 |
| 9 Features | 32 |
| 9.1 Resonance-based Sound Design | 32 |
| 9.2 Phase-Optimised Filtering | 32 |
| 9.3 Automatic Bass Linearisation (ABL) and Thermal Protection | 32 |
| 9.4 Thermal Compression Compensation | 33 |
| 9.5 Production “Cloning” | 33 |
| 10 Technical Specifications | 34 |
| 10.1 Total System | 34 |
| 10.2 Preamplifier and Processor Section | 34 |
| 10.2.1 Overall Specifications | 34 |
| 10.2.1.1 Digital input to DAC outputs | 34 |
| 10.2.2 Inputs | 34 |

| | |
|---|-----------|
| 10.2.2.1 Analogue Inputs | 34 |
| 10.2.2.2 Digital Inputs | 35 |
| 10.2.3 Digital Signal Processor | 36 |
| 10.2.4 Digital to Analogue Converters | 36 |
| 10.3 Power Amplifiers | 37 |
| 10.3.1 Tweeters and Midrange Sections | 37 |
| 10.3.2 Woofer Section | 37 |
| 10.4 Loudspeaker Drivers | 37 |
| 10.4.1 Tweeters | 37 |
| 10.4.2 Midranges | 37 |
| 10.4.3 Front Woofer | 38 |
| 10.4.4 Woofers | 38 |
| 10.5 Power Supply | 38 |
| 10.6 Digital Power Link | 38 |
| 11 FAQ | 39 |
| 11.1 Multichannel system setup | 39 |
| 11.1.1 Bang & Olufsen television as source | 39 |
| 11.1.2 Third-party device as source | 39 |
| 11.2 Does Beolab 90 support DSD? | 39 |
| 11.3 Does Beolab 90 support DXD? | 39 |
| 11.4 Why does the Beolab 90 sound “different” when I switch to watching television? | 39 |
| 12 Setup “Tips and Tricks” | 40 |
| 13 Troubleshooting | 41 |
| 13.1 Some features in the Beolab 90 controls are disabled | 41 |
| 13.2 Echo problems | 41 |
| 13.2.1 Multiroom audio systems | 41 |
| 13.2.2 Surround Processors | 41 |
| 13.3 Loudspeakers don’t turn on automatically | 41 |
| 13.4 Loudspeakers never shut off | 41 |
| 13.4.1 Analogue sources | 41 |
| 13.4.2 Digital sources | 41 |
| 13.4.2.1 S/PDIF and Optical | 41 |
| 13.5 The application and/or web interface do not work | 41 |
| 13.6 Loudspeakers are distorting at low levels | 41 |
| 13.7 Loudspeakers are noisy / too quiet | 41 |
| 13.8 USB Audio not working | 41 |
| 13.9 S/PDIF input not working | 42 |
| 13.10 Optical input not working | 42 |
| 13.11 Automatic switching of inputs not behaving as expected | 42 |
| 14 Appendix 1: Recommendations for Critical Listening | 43 |
| 14.1 Loudspeaker Configuration | 43 |

| | | |
|-----------|--|-----------|
| 14.2 | Listening Room Acoustics | 44 |
| 14.3 | Loudspeakers | 44 |
| 14.4 | Source Devices | 44 |
| 14.5 | Cable recommendations | 45 |
| 14.5.1 | Analogue cables | 45 |
| 14.5.2 | Optical cables | 45 |
| 14.5.3 | S/PDIF cables | 45 |
| 14.6 | AC mains cables | 45 |
| 15 | Appendix 2: Introduction to Parametric Equalisers | 46 |
| 15.1 | Filter Type | 46 |
| 15.1.1 | Low-shelving Filter | 46 |
| 15.1.2 | High-shelving Filter | 46 |
| 15.1.3 | Peaking Filter | 47 |
| 15.2 | Gain | 47 |
| 15.3 | Centre Frequency | 47 |
| 15.4 | Q | 47 |
| 16 | Appendix 3: The Influence of Listening Room Acoustics on Loudspeakers | 49 |
| 16.1 | Early Reflections | 49 |
| 16.2 | Room Modes | 51 |
| 16.3 | Reverberation | 52 |
| 16.4 | Solutions | 52 |
| 16.5 | Conclusions | 52 |
| 17 | Appendix 4: Loudspeaker Directivity and Distance Perception in Stereo Imaging | 54 |
| 17.1 | Distance Perception in Real Life | 54 |
| 17.2 | Distance Perception in a Stereo Recording | 54 |
| 17.3 | Combining the Two | 54 |
| 18 | Appendix 5: Microphone placement strategy when creating ARC Zones | 55 |
| 18.1 | General information | 55 |
| 18.1.1 | Background noise | 55 |
| 18.1.2 | Microphone Orientation and Holder | 55 |
| 18.1.3 | Height | 55 |
| 18.1.4 | Doors and Windows | 55 |
| 18.2 | One listening position | 55 |
| 18.3 | More than one listening position | 56 |
| 19 | Appendix 6: ABL - Adaptive Bass Linearisation | 57 |
| 19.1 | A General Introduction to ABL | 57 |
| 19.2 | ABL and Beolab 90 | 58 |
| 20 | Appendix 7: Thermal Compression Compensation | 59 |
| 20.1 | Introduction | 59 |
| 20.2 | Voice coil temperature | 59 |
| 20.3 | Loudspeaker response changes | 60 |

| | | |
|--------------|---|-----------|
| 20.4 | The solution | 61 |
| 20.5 | Some extra information | 61 |
| 21 | Appendix 8: Control of Beolab 90 using the BeoRemote 1 | 62 |
| 21.1 | Introduction | 62 |
| 21.1.1 | Customising the Product Name | 62 |
| 21.2 | Input Selection | 62 |
| 21.2.1 | Source Selection | 62 |
| 21.2.2 | Customising the Input Names | 62 |
| Index | | 63 |

Quick Setup Guide

It is probably simplest to edit one of the factory-default Speaker Presets when doing a first-time setup. This can be done using the steps outlined below.

In order to access all configuration parameters, it is necessary to use the web-based user interface. This can be done in one of two ways. The first is via the Bang & Olufsen app for iOS or Android devices. The second is to access the web interface directly using a web browser.

Using the Bang & Olufsen app:

- Open the Bang & Olufsen app for iOS or Android devices and add the BeoLab 90s as a new product.
- Add, and then Select the BeoLab 90s from your list of products.
- Scroll down and click on "Product settings" under the "Product information" header.
- Click on "Configure" to enter the web interface of the loudspeakers to access all configuration parameters.

Using a web browser:

- Enter the IP address of your BeoLab 90s in the URL field of a web browser.

In the web interface:

Enter the edit mode by pressing the "..." icon on the top right of the screen and select the Preset you wish to modify, or press the "+" icon to create a new preset.

Enter the Beam Control menu and do the following:

- Select the desired Beam Width and Beam Direction, if applicable.
- Assign the appropriate Speaker Role (Left / Right) to the Primary loudspeaker.
- Set the Distances from each loudspeaker to listening position.
- Set the Speaker Levels at listening position.

After this is complete, it is advisable to create an Active Room Compensation (ARC) filter. To start this process, connect the microphone to the panel on the back of the Primary loudspeaker and enter the ARC menu.

- Enter the edit mode by pressing the "..." icon on the top right of the screen.
- Press the "+" icon to create a new ARC filter.
- Follow the instructions for microphone placement and perform the three measurements.
- After the measurement procedure is complete, select the

ARC filter you have made to apply it to the listening Preset.

Note: Until you select the ARC filter, it is not applied to the audio signal.

Enter the "Advanced" menu

- Verify that the Latency Mode is set to "Auto".
- If your source is a Bang & Olufsen television, take note of the Preset Number in this menu.

Rename the Preset if desired.

The loudspeakers are now optimised for a third-party source and ready for use.

If the BeoLab 90s are connected to a Beovision television:

- Create a Speaker Group in the television.
- Include the BeoLab 90s in the "Speaker Connections" menu.
- Assign the appropriate Speaker Roles to the loudspeakers.
- Set the Distances from each loudspeaker to listening position.
- Set the Speaker Levels at listening position.
- Assign the Speaker Preset in the Beovision menu to match the appropriate Preset number in the BeoLab 90s.

Introduction

The Beolab 90 is a loudspeaker concept from Bang & Olufsen that gives the customer an unprecedented level of control of its acoustic behaviour and performance. Unlike almost all other conventional loudspeakers, the Beolab 90 can be altered by the user to behave as if it were completely different loudspeakers for different listening situations.

Imagine that you have a pair of Beolab 90 loudspeakers, perfectly positioned in your listening room, with a single chair in the correct location, as is shown in Figure 2.1. You sit in this chair to listen to a recording; to hear sparkling high frequencies and a tight, punchy bass that extends to the lowest audible frequency bands along with the accurate and precise placement of the instruments within the space in front of you (better known as “stereo imaging”).

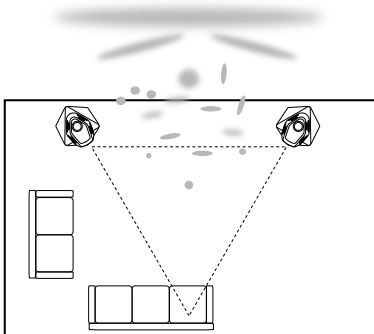

Figure 2.1: The sound stage presented by Beolab 90s for active listening when sitting in the sweet spot with properly placed loudspeakers.

Now, imagine that you have the same loudspeakers in the same positions in the same room, but you’ve moved to the sofa as shown in Figure 2.2 (or perhaps you’re still in the same sofa as before as shown in Figure 2.3) and you prefer to hear music in the background while you read a book. In this case, the bass precision and the imaging of the recording are not important: you just want a cloud of sound that does not distract you while you read. Using your controller you simply switch the

behaviour of the Beolab 90s to deliver this experience instead.

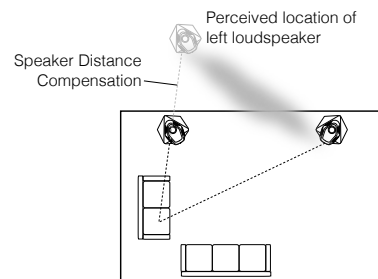

Figure 2.2: The sound stage presented by Beolab 90s for passive listening when not sitting in the sweet spot.

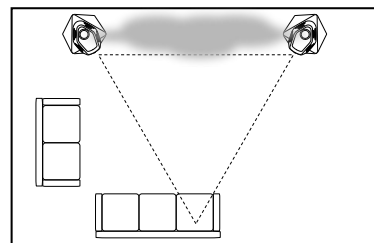

Figure 2.3: The sound stage presented by Beolab 90s for passive listening when sitting in the sweet spot.

Finally, imagine that you invite your friends for a party or you’re just walking around the room. Imaging is of no interest to anyone: you want a loudspeaker that can deliver the same experience to the entire room at the same time by sending sound in all directions simultaneously. Again, with your controller, you change the Beolab 90’s acoustical behaviour to suit the occasion.

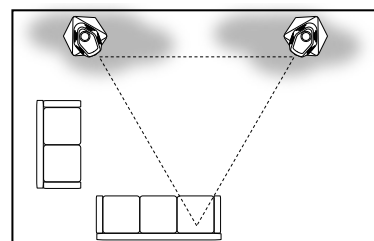

Figure 2.4: The sound stage presented by Beolab 90s for background music when the listeners are moving around the room.

These three scenarios illustrate the primary listening modes that the Beolab 90 can deliver. We’ll call the first one **active listening**, since your primary activity is to listen to the recording. We’ll call the second one **passive listening** since, in this case, listening to music is secondary to another activity (in our example, reading) in a stationary listening position or area. We’ll call the third case **background music** which is similar to passive listening, however, there is no determined listening position (either because there are many listeners, or listeners are moving around the listening area, or both). In order to be able to do this, there are different adjustable parameters in the Beolab 90. You can choose to alter each of these parameters individually according to your preferences and listening situations, and then save the settings to a preset for future use.

2.1 Features

Beolab 90 gives you the power to make these changes using a large number of “handles” – controllers that let you change the acoustical behaviour of the loudspeaker. Among these features, there are three that stand out:

- Beam Width Control
- Beam Direction Control
- Active Room Compensation

In addition to these, the Beolab 90 has a many other parameters that give you a wide range of customisation possibilities such as:

- Speaker Distance for time-alignment at the listening position
- Speaker Level
- Basic tone controls: Bass and Treble
- 10-band Parametric Equaliser

2.1.1 Beam Width Control

When a recording engineer makes a recording in a well-designed studio, he or she is sitting not only in a carefully-designed acoustical space, but a very special area within that space. In many recording studios, there is an area behind the mixing console where there are no reflections from the sidewalls arriving just after the direct sound from the loudspeakers. This is implemented either by putting acoustically absorptive materials on the walls to “soak up” the sound so it cannot reflect (as shown in Figure 2.5), or by angling the walls so that the reflections are directed away from the listening position (as shown in Figure 2.6).

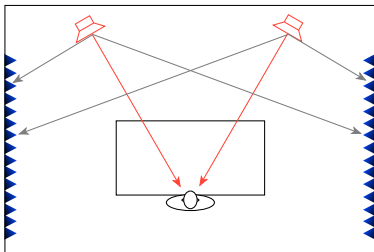

Figure 2.5: One way to reduce the problem of side wall reflections is to absorb them at the walls so that there is no reflection. This is a solution often used in recording studios, however, it also results in an unnatural-sounding “dead” room.

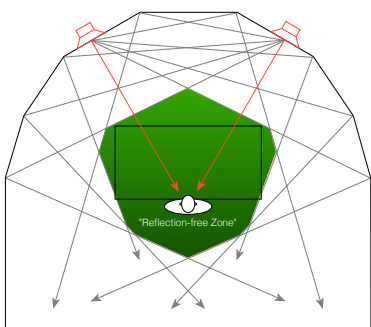

Figure 2.6: An alternative method to reduce the problem of side wall reflections is to re-direct them away from the listening position, producing a “reflection-free zone”. This method is often used in recording studios that are initially designed with the help of an experienced acoustical consultant.

This is different from your living room

which has not been designed primarily as an acoustical space. It probably has sidewalls that reflect the energy from your loudspeakers and send that sound to you at the listening position – a situation that is more like that which is shown in Figure 2.7.

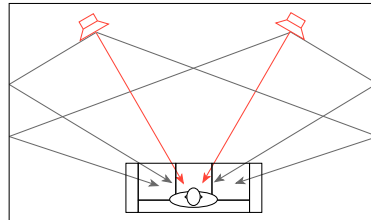

Figure 2.7: The direct sound (in red) from the loudspeakers is influenced by the reflections off the side walls (in grey).

In order to get the same acoustical behaviour in your living room that the recording engineer had, we have to reduce the amount of energy that is reflected off the side walls. If we do not want to change the room, one way to do this is to change the behaviour of the loudspeaker by focusing the beam of sound so that it stays directed at the listening position, but it sends less sound to the sides, towards the walls.

This is one of the options that Beolab 90 gives you – to make the beam of sound directed out the front of the loudspeaker narrower to reduce the level of sidewall reflections, so that you get a more accurate representation of the sound the recording engineer heard when the recording was made.

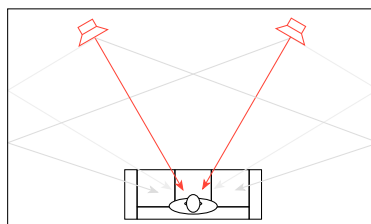

Figure 2.8: Beolab 90 solves the problem of side wall reflections by reducing the amount of acoustic energy that is radiated towards the side walls – so there is less energy to reflect.

However, if you’re sharing your music with friends or family, depending on

where people are sitting, the beam may be too narrow to ensure that everyone has the same experience. In this case, it may be desirable to make Beolab 90’s sound beam wider.

Of course, this can be extended to its extreme where the Beolab 90’s beam width is extended to radiate sound in all directions equally. This may be a good setting for cases where you have many people moving around the listening space, as may be the case at a party, for example.

This option to change the pattern of the radiation of sound from the Beolab 90 is called *Beam Width Control*.

2.1.2 Beam Direction Control

Almost all loudspeakers are designed to radiate sound forwards – so, in order to get the best experience from your loudspeakers, you have to be located directly in front of them. However, Beolab 90 gives you the freedom to change the direction of the sound beam directed from the loudspeaker. You can select one of five directions as being the “acoustical front” of the loudspeaker. If you’re sitting to the side of the loudspeaker as is shown in Figure 2.2 you can choose to rotate the sound beam so that it is directed more towards your listening position instead of in front of the loudspeakers.

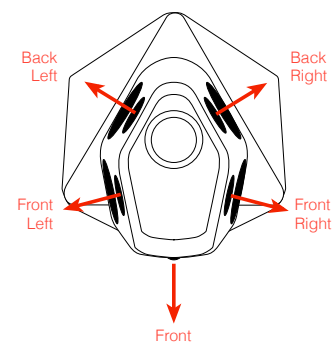

Figure 2.9: Beolab 90 has five beam directions available, allowing you to optimise for different listening positions.

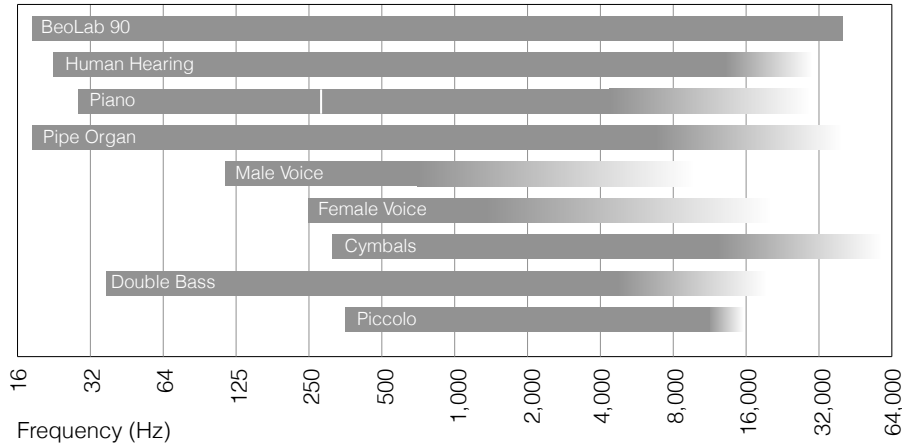

Figure 2.10: The approximate frequency ranges of example sound sources. The darker grey bars show the frequency ranges of the fundamental frequencies. The gradient bars show the harmonic content. The white line in the Piano range shows "Middle C". BeoLab 90's frequency range is shown for comparison.

2.1.3 ARC: Active Room Compensation

In 2002, Bang & Olufsen introduced the Beolab 5 which included *ABC - Automatic Bass Calibration*. This was a system that used a microphone to measure the effects of the listening room's acoustical behaviour on the sound of the loudspeaker, and then created a filter that compensated for those effects in the low frequency band. As a very simple example, if your room tended to increase the apparent bass level, then the Beolab 5's would reduce their bass level by the same amount.

Beolab 90 takes this concept to a new

level with its *Active Room Compensation* or *ARC*. Using an external microphone (available from your Bang & Olufsen dealer), you can measure the effects of your room's acoustical behaviour in different zones in the room and subsequently select optimised compensation filters for different situations. For example, you can customise a filter for the sofa, and another for your dining area. In cases where you are moving between these locations, you can create a third filter that combines the results from both measurements, thus improving the sound experience in both locations simultaneously.

The Beolab 90 also offers another development in acoustical room

compensation: multichannel processing. This means that the loudspeakers not only "see" each other as having an effect on the room - but they help each other to control the room's acoustical influence.

2.1.4 Performance

Beolab 90 has been designed from the outset to deliver an unparalleled audio performance. Measured directly in front of the loudspeaker, it has a frequency range that exceeds the limits of human hearing at normal listening levels as can be seen in the comparison plot in Figure 2.10. (see the [Technical Specifications](#) on Page 34 for more details).

User Interface

3.1 Daily use with the Bang & Olufsen app

The Bang & Olufsen application for iOS or Android devices is primarily designed for daily use of the Beolab 90s. System setup and configuration of the Speaker Presets should be done using the web-based interface, described below.

After opening the app and selecting the Beolab 90s, the display will be similar to the example shown in Figure 3.2.

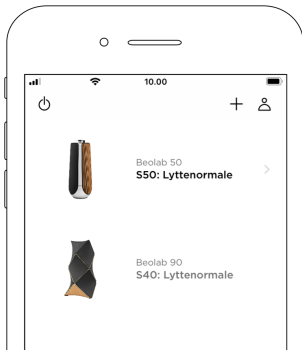

Figure 3.1: The entry page for the Bang & Olufsen app.

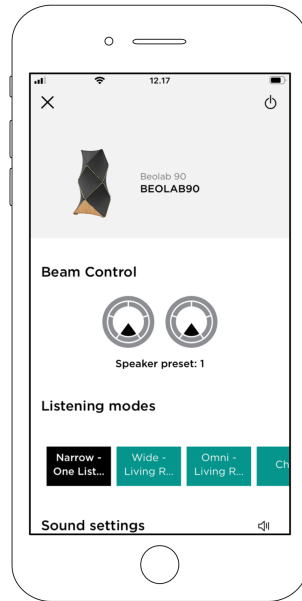

Figure 3.2: The entry page for the daily use area of the Beolab 90. You can scroll down on this screen to show additional options, shown in Figure 3.3.

To select a pre-programmed Listening Mode, click on the appropriate rectangle under “Listening modes”¹. The current mode is shown in black and the other available modes are displayed in blue-green. Additional available modes can be seen by swiping the list left and right.

In order to edit the configuration of the current Listening mode, click on the icons representing the loudspeakers’ Beam Widths under the “Beam Control” heading. This will take you to the screen shown in Figure 3.4.

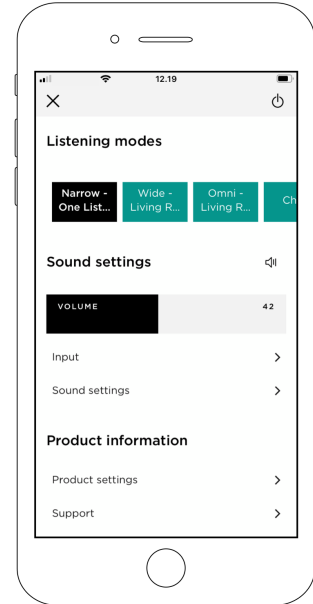

Figure 3.3: The bottom portion of the entry page for the daily use area of the Beolab 90. The speaker icon on the right of “Sound settings” is the mute control.

The “Sound Settings” portion of the screen contains the mute control (shown as a small speaker icon on the right of the screen), the volume control, and links to two additional screens.

The volume cannot be increased higher than the “Maximum Volume”, set in the “Sound Settings” screen (Figure 3.6)

The “Product Information” portion of the screen contains links to two other displays with additional controls.

¹Listening Modes and Speaker Presets are equivalent terms for the same feature.

²All of the features listed here are described in detail later in this manual.

The Beam Width, Beam Direction, Speaker Role (Left / Right), Speaker Distance, and Speaker Level² are adjusted in the Beam Control display, shown in Figure 3.4. For additional editing of the Preset, it is necessary to enter the web interface, described below in Section 3.2.

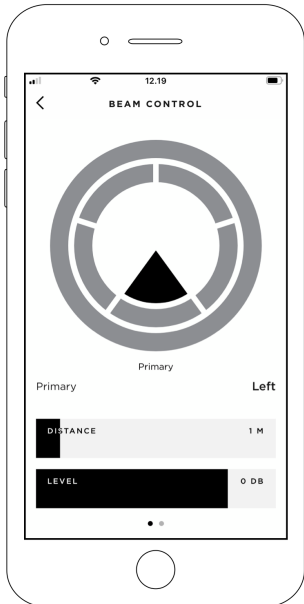

Figure 3.4: The Beam Control display for the primary loudspeaker. Swipe to the left for the secondary loudspeaker.

The Input display, shown in Figure 3.5, can be used to manually select the current input from a third-party source. Note that an input is enabled only if signal is detected. See Section 6.1 for more detailed information.

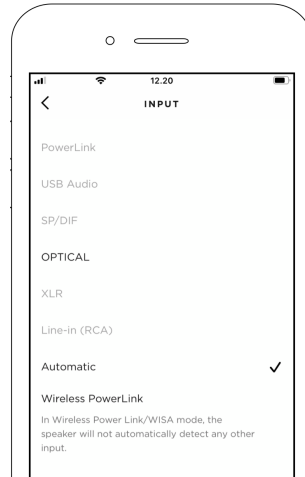

Figure 3.5: The Input display for manual selection of signals arriving at the various inputs.

The “Sound Settings” display, shown in Figure 3.6, gives you the opportunity to adjust the default (start-up) volume setting used for third-party sources. You can also adjust the maximum volume if you wish to avoid accidentally playing signals at extreme levels.

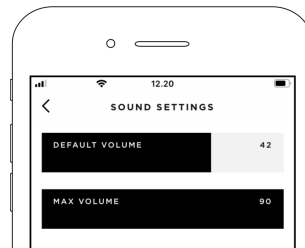

Figure 3.6: The default start-up volume and maximum volume for third-party sources can be adjusted in the Sound Settings display.

The “Product Settings” window, shown in Figure 3.7, contains the following options:

- “Configure” enters the web-based user interface for setup.

- “Product color” can be used to change the way the Beolab 90 is displayed in the Bang & Olufsen app.
- “Name” can be used to change the name of the loudspeakers displayed in the Bang & Olufsen app.
- “Software” displays the current software version in the loudspeakers. You can also enable and disable the Automatic Update feature in this menu.
- “About” enters a display screen that shows various items of information about the loudspeakers, including the IP Address
- “Remove Product” (at the bottom of the screen) will remove the Beolab 90s from the list of available products in the app.

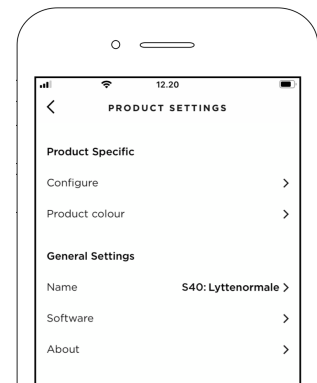

Figure 3.7: The “Product Settings” display.

3.2 Navigation within the web interface

The web-based interface can be used for daily use, but it also permits access to all configuration parameters in the Beolab 90s for setup and personalisation.

There are two ways to enter this interface.

Using the Bang & Olufsen app:

- Open the Bang & Olufsen app for iOS or Android devices and add the BeoLab 90s as a new product.
- Select the BeoLab 90s from your list of products.
- Scroll down and click on "Product settings" under the "Product information" header.
- Click on "Configure" to enter the web interface.

Using a web browser:

- Enter the IP address of your Beolab 90s in the URL field of a web browser.³

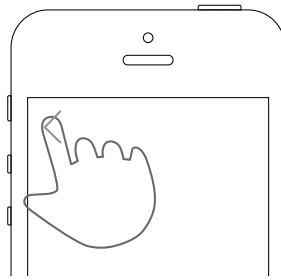

Figure 3.8: Press the left-pointing arrowhead at the top left of the screen to return to the previous menu.

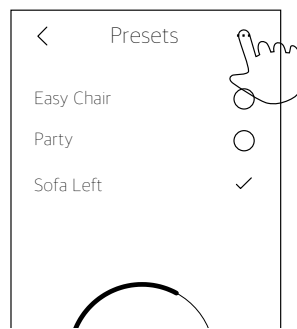

Figure 3.9: Press the "... " icon in the top right to switch to the edit mode for the current screen.

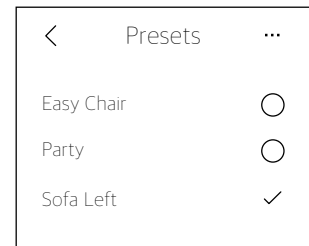

Figure 3.10: Circular selection buttons allow for one item from the list to be chosen.



Figure 3.11: Rounded square selection buttons are toggles that allow for more than one item from the list to be chosen.

³The IP Address can be found using the Bang & Olufsen App by navigating to "Product settings", then "About". Alternatively, you can find the IP Address via your router's information page, or using an application that displays IP Addresses of devices on your network.

3.3 Menu Map

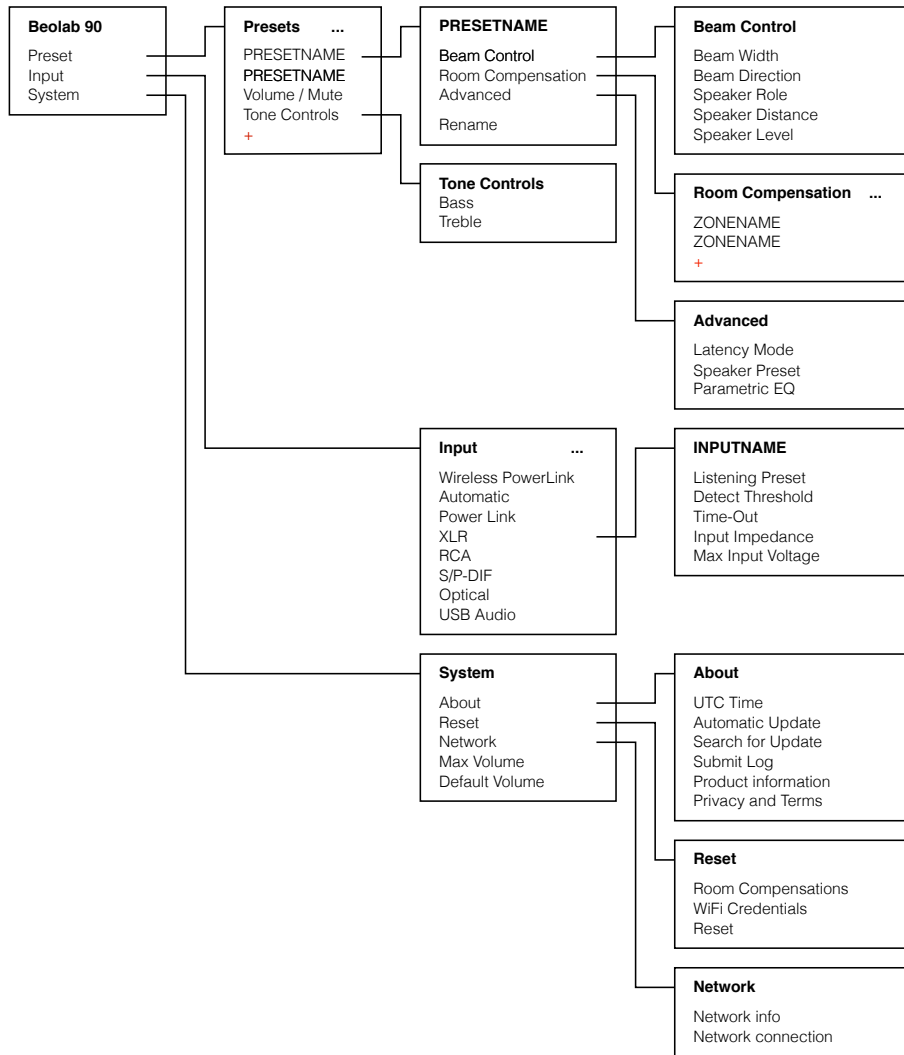

Figure 3.12: Simplified and generalised navigational map for the Beolab 90 interface. Some items shown above are only visible when the menu is in edit mode which is entered by pressing the “...” icon at the top right of some menus. Also, not all parameters are available for all items (e.g. different inputs have different options).

Presets

4.1 What is a Preset?

Almost all parameters that can affect the audio characteristics of the Beolab 90 can be pre-programmed and saved as a *preset*¹ that is easily and quickly selectable by the end user. A preset contains a wide range of controls that can be customised to suit both the listener's personal preferences and his or her location in the listening room.

Presets can either be selected manually using the Beolab 90 interface or they can be selected automatically as is explained in [Automating Preset Selection](#) on page 26.

4.2 Preset management

4.2.1 Selecting a Preset

The list of currently-available presets are shown in the Preset Select menu, an example of which is shown in Figure 4.1. From this menu, you can manually select a preset by clicking on its icon as shown.

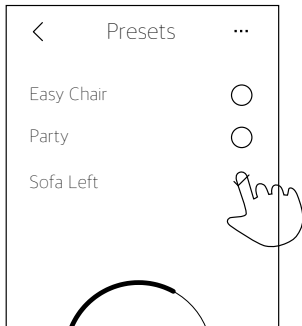

Figure 4.1: Select a Preset by pressing its icon on the right of the screen as shown. The currently-selected Preset is indicated with a check mark.

4.2.2 Creating and Editing a Preset

To modify an existing preset or to create a new preset, enter the Edit Preset menu by pressing the '...' icon on the top right of the screen as shown in Figure 4.2.

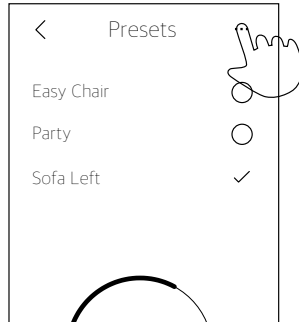

Figure 4.2: Press the three dots at the top right of the screen to enter the edit mode.

In order to create a new preset, enter the edit mode (as shown in Figure 4.2) and press the "+" icon in the Preset menu. This will start a process where you can name the preset and edit its parameters.

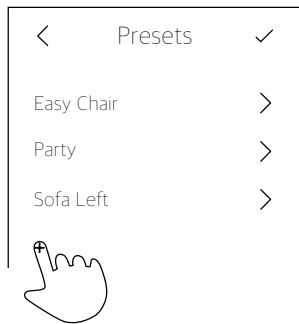

Figure 4.3: Press the "+" icon to create a new preset. Note the check mark on the top right of the screen which indicates that we have entered the "edit" mode.

To edit the parameters of an existing preset, press its associated icon after you have entered the preset menu's edit mode.



Figure 4.4: Press anywhere on a preset's line to begin to edit its parameters.

4.2.3 Deleting a Preset

In order to delete a preset, enter the preset menu's edit mode and swipe to the left at any position in the row. This will reveal an "x" on the right side of the screen. Pressing the "x" will delete the preset.

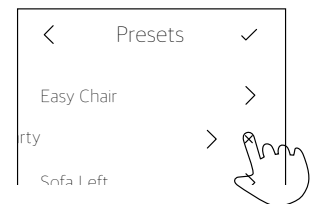
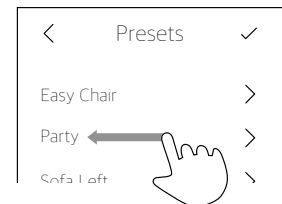

Figure 4.5: An example of deleting a preset. To delete the "Party" preset, swipe to the left on its row. This will reveal the "x" on the right of the screen. Press the "x" to delete the preset.

¹Presets are sometimes called "Listening Modes" or "Modes" in the Bang & Olufsen app.

early lateral reflections in the listening position.

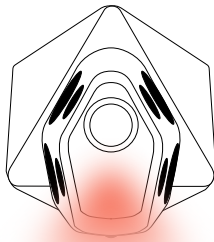

Figure 5.5: Conceptual drawing showing the beam width of the Narrow Beam.

You should note, however, that there are side-effects to using a narrow beam width. The most obvious may be in the low frequency behaviour of your Beolab 90s. Generally, the overall impression will be that the bass content is “tighter” or has more “punch” when the Beolab 90 is in narrow mode. However, this effect is also dependent on the setting of another parameter described in [Latency Mode](#) on page 23.



Figure 5.6: Press the sector (or “pizza slice”) on the Beolab 90 interface to change the Beam Width to Narrow.

A second potential side effect is the sensitivity of the system to an incorrect listening position. You may notice that, in narrow mode, it is critical that you are seated at exactly the correct listening position in order to achieve both precise and accurate stereo imaging. Small deviations in listening position may result in noticeable detriments in the spatial representation of your recordings.

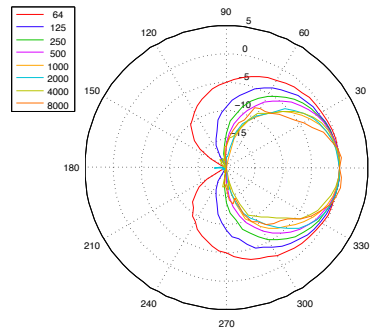

Figure 5.7: Polar plot of the directivity of the Narrow Beam. Latency: Long

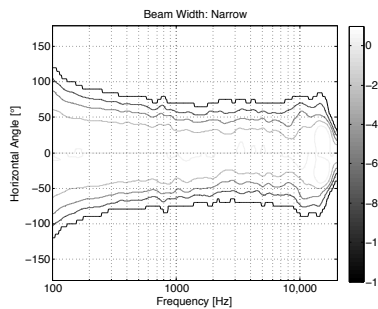

Figure 5.8: Full frequency range directivity plot of the Narrow Beam. Latency: Long. Contours in steps of 3 dB, normalised to the on-axis response.

5.1.2 Wide

As mentioned above, when the Beolab 90s are set to a narrow beam width, they are somewhat unforgiving of a mis-placement of the listening position. This is particularly noticeable when you are listening to with friends and family.

Consequently, in more social or passive listening situations, it is likely preferable that the Beolab 90s have a wider beam width. Although this will likely result in more energy in the sidewall reflections, it also ensures that there is a more equal distribution of the direct sound across a wider listening area in the room.

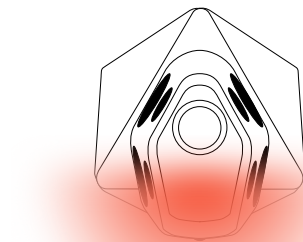

Figure 5.9: Conceptual drawing showing the beam width of the Wide Beam.



Figure 5.10: Press the curved line shown above to change the Beam Width to Wide (Front).

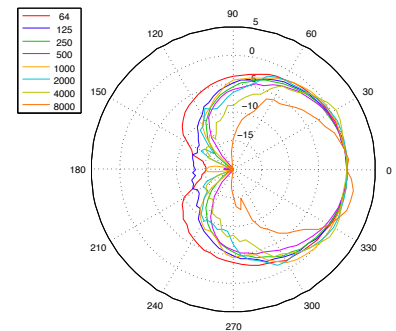

Figure 5.11: Polar plot of the directivity of the Wide Beam. Latency: Long

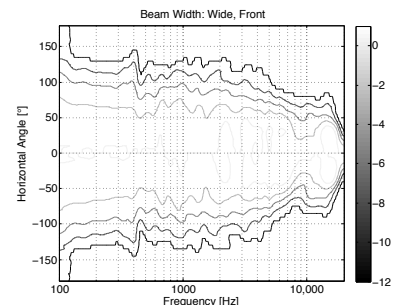

Figure 5.12: Full frequency range directivity plot of the Wide Beam. Latency: Long. Contours in steps of 3 dB, normalised to the on-axis response.

The side effects of the Wide beam width are dependent on the strength of the sidewall reflections, however, in many situations, four different effects may be audible.

The first is that the apparent distance to the various sources in the stereo mix will collapse slightly, resulting in the perception that the sources in the recording are roughly the same distance from the listening position as the loudspeakers themselves. This means that (relative to the narrow mode) very close sources will move further away and very far sources will move closer to the listening position.

Secondly, the apparent width of the sources will become slightly larger with less precise left-right locations. You will not have pinpoint locations as in narrow mode - the imaging becomes slightly more "cloudy" or "fuzzy". This is due to the extra energy reflected off the side walls.

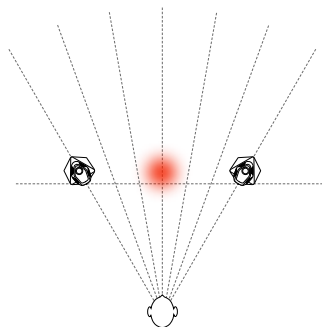

Figure 5.13: A map of the phantom image location of the voice (shown in red) in Suzanne Vega's recording of Tom's Diner. Beam Width: Wide. Compare to Figure 5.3

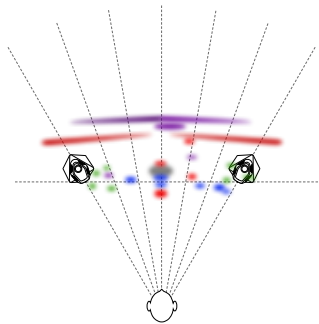

Figure 5.14: A map of the phantom image locations of instruments and voices in Jennifer Warnes's recording of Bird on a Wire. Beam Width: Wide. Compare to Figure 5.4

Thirdly, the overall timbre or tone colour of the sound may change as a result of increase influence of the sidewall reflections at the listening position.

Finally, as mentioned above, the overall "punch" of the bass will change when compared to the narrow mode.

5.1.3 Omni

In some situations, it may be preferable that the Beolab 90s radiate sound in all directions equally. One example of this are when you are throwing a party and have many guests listening to music simultaneously from many different locations in the room. Another example is when you have fewer persons in the room, but they are moving around to different locations and simply want background music while they do so.

In such situations, you can set the Beolab 90s to deliver an "Omni" beam width where sound is radiated equally in all directions in the horizontal plane.

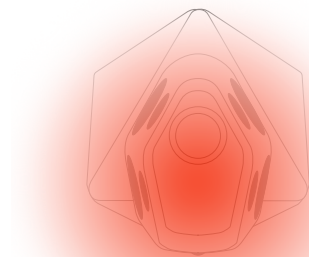

Figure 5.15: Conceptual drawing showing the beam width of the Omnidirectional (Omni) Beam.



Figure 5.16: Press the outside circle in the Beam Control menu to change the Beam Width to Omni.

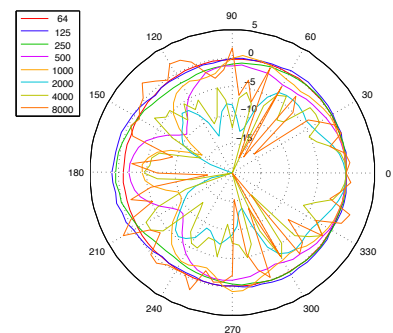

Figure 5.17: Polar plot of the directivity of the Omni Beam. Latency: Long

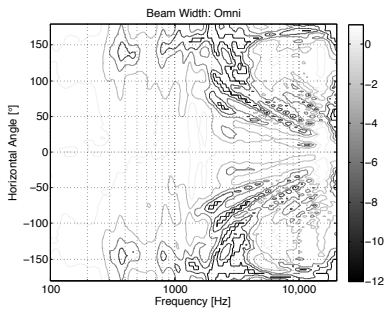

Figure 5.18: Full frequency range directivity plot of the Omni Beam. Latency: Long. Contours in steps of 3 dB, normalised to the on-axis response.

The side effects of the Omni beam width are similar to those of the Wide beam width - the only difference is that they are more noticeable. Distances to sound sources become even more similar to the distance the loudspeakers, left-right imaging becomes less precise (but more forgiving of incorrect listener placement), and the influence of wall reflections becomes more audible.

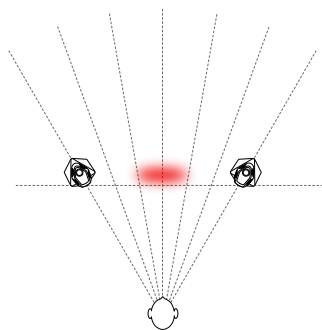

Figure 5.19: A map of the phantom image location of the voice (shown in red) in Suzanne Vega's recording of Tom's Diner. Beam Width: Omni. Compare to Figure 5.3

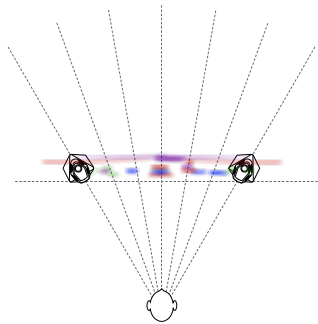

Figure 5.20: A map of the phantom image locations of instruments and voices in Jennifer Warnes's recording of Bird on a Wire. Beam Width: Omni. Compare to Figure 5.4

In addition, in cases where the loudspeakers are located near a front wall, the timbral effects of reflections from behind the loudspeakers may also become more audible.

Experienced readers will notice that, although in the low frequency bands, the "omni" setting results in an omnidirectional directivity, there are measurable "lobing" effects in the higher frequency bands. This is primarily caused by the distances between the midrange and tweeters which have been optimised for the narrow beam width, however, in a passive listening or background music situation, this will not detract from the overall performance of the loudspeaker.

5.1.4 Comment

The above illustrations connecting Beam Widths to listener position are merely that - illustrations. It should also be said that changing the Beam Width of the Beolab 90 has non-intuitive consequences on the perceived sound of the loudspeakers. For example, the overall sensation of "punch" in the bass may be different for the three Beam Widths, regardless of your location in the listening room. Consequently, it may be that you prefer the overall sound of a particular Beam Width, even if you are not sitting "in the beam".

5.2 Beam Direction Control

There may be cases where you are sitting off-axis to the loudspeakers, far away from the so-called "sweet spot" in the listening room. Depending on the placement of your loudspeakers, this may even include listening positions that are behind the loudspeakers. In these situations, it may be desirable to change the principal direction of radiation of the sound from the Beolab 90s, rotating the beam so that it is better directed towards the listening position. This is possible using the Beam Direction Control feature of the Beolab 90.

When the Beam Width is set to "Wide", it is possible to change the direction of the beam by selecting from five options:

- Front
- Front Left
- Front Right
- Back Left
- Back Right

These five directions are illustrated in Figure 2.9 as well as Figures 5.9, 5.22, and 5.23.

The Beam Direction control is only available when the Beam Width control is set to "Wide". This is because the narrow beam width is only possible due to the cluster of three tweeters and three midrange drivers on the front of the loudspeaker. Also, since the omni beam width is circular, its rotation would be redundant.



Figure 5.21: Press the curved line shown above to change the Beam Width to Wide with a Left Front direction.

The beam directions of the two Beolab 90s in a pair are independent,

however, if you are adjusting the Primary loudspeaker's direction, the Secondary loudspeaker's direction will be automatically adjusted to match. (e.g. If you set the Primary to Left Back, then the Secondary will also be set to Left Back.) If you would like the loudspeakers to be directed in two different directions (e.g. Left Back and Right Front), you should adjust the Primary loudspeaker first, and then adjust the Secondary.

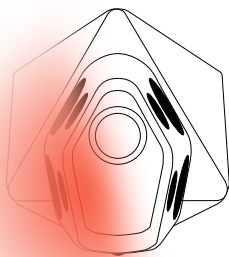

Figure 5.22: Conceptual drawing showing the beam width of the Medium Beam in the Left Front direction.

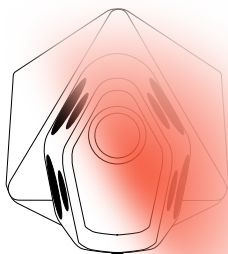

Figure 5.23: Conceptual drawing showing the beam width of the Medium Beam in the Right Back direction.

Note that, if an Active Room Compensation zone has been created, and is applied to the Preset you are currently editing, then an appropriate filter setting will be calculated each time you change Beam Direction. This calculation takes approximately 20 seconds to perform, and is indicated by a progress wheel. If you wish to

audition differences in Beam Direction more quickly, this can be done by disabling the ARC filter for the Preset in the Room Compensation menu.

5.3 Speaker Distance

The *Speaker Distance* control is used to ensure that the times of arrival of the loudspeakers' signals at the listening position are matched, despite being placed at different distances from the listening position. The value displayed on the menu should be the distance from the listening position to each loudspeaker. The result of this alignment is that the closer loudspeaker's signal is delayed to match the time of arrival of the sound from the more distant loudspeaker.

Note that, since the Listening Position can be different for different Presets, these distances may not necessarily be the same from Preset to Preset.

If your only source is a Beovision television, then the Speaker Distances should be entered in the television's Speaker Group menu instead of in the Beolab 90's preset.

| Units | Metres |
|-----------------|------------|
| Range (m) | 0.0 - 10.0 |
| Resolution | 0.1 m |
| Factory Default | 1.0 m |

5.3.1 Adjusting Speaker Distances with a rotated Beam Direction

If you are measuring the Speaker Distances manually, then the measurement should be made from the listening position to the tweeter associated with the Beam Direction as illustrated in Figure 5.25.

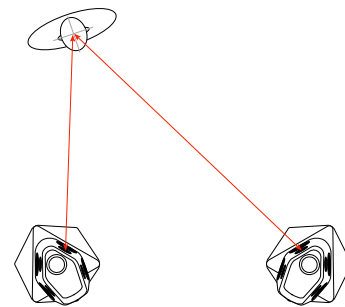

Figure 5.25: The Speaker Distance for each loudspeaker should be measured from the listening position to the relevant tweeter for the given Beam Directions.

5.3.2 Adjusting Speaker Distances for more than one listening position

In a case where there is more than one listener present, the Speaker Distances can be optimised by measuring each loudspeaker's position relative to the closest listening position, as is shown in Figure 5.26.

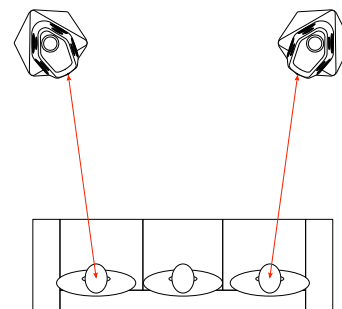

Figure 5.26: The Speaker Distance for each loudspeaker should be measured from the relevant tweeter for the given Beam Directions to the closest listening position.

5.4 Speaker Level

The sensitivity of any two Beolab 90s has been calibrated during their creation to be within 0.2 dB of each other at any third-octave frequency band within their frequency range. However, there are cases where, due to placement in the listening room, room acoustics, or the listening position relative to the loudspeakers, you may wish to fine-tune the relative

levels of the two loudspeakers. This can be done with the Speaker Level adjustment.

The Speaker Levels should be adjusted at the listening position. Note that this can be performed either before or after an Active Room Compensation profile has been created - the ARC compensates for any adjustments automatically.

The Speaker Level for each Beolab 90 in the pair is adjusted from the Beam Control menu, shown in Figure 5.1.

If your only source is a Beovision television, then the Speaker Levels should be entered in the television's Speaker Group menu instead of in the Beolab 90's preset.

5.5 Speaker Role

The Beolab 90 is created as a pair of loudspeakers - one "Primary" loudspeaker which has the connection panel for the input signals and one "Secondary" loudspeaker.

Since both the left and right audio channels are input to your Primary loudspeaker, there is no physical way of knowing which loudspeaker is on the left and which is on the right (compare Figures 5.27 and 5.28 as an example). As a result, the interface allows you to swap the Speaker Role, to ensure that the correct audio channel is reproduced by the correct loudspeaker.

The selection of Left or Right for the Primary and Secondary loudspeakers is done in the Beam Control menu, shown in Figure 5.1.

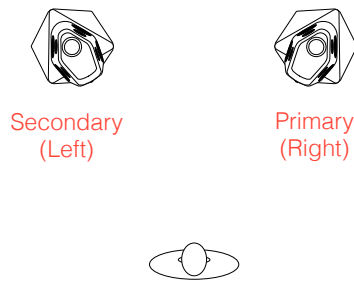

Figure 5.27: An example of a loudspeaker configuration where the Primary loudspeaker should be assigned the Speaker Role of "right".

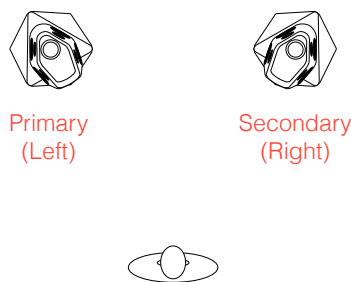

Figure 5.28: An example of a loudspeaker configuration where the Primary loudspeaker should be assigned the Speaker Role of "left".

In addition to this, since the beam direction can be rotated to the back of the loudspeakers, it is possible that, for some presets, you will wish to swap the left and right Speaker Roles (compare Figures 5.28 and 5.29 as an example).

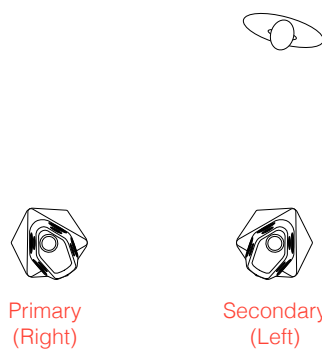

Figure 5.29: An example of a loudspeaker configuration where the Primary loudspeaker should be assigned the Speaker Role of "right".

If your only source is a Beovision television, then the Speaker Role should be entered in the television's

Speaker Group menu instead of in the Beolab 90's preset.

Note that a Primary / Secondary pair of Beolab 90s cannot share the same Speaker Role. If you wish to send the same audio signal out of both loudspeakers, this will have to be arranged using the source device.

5.6 Active Room Compensation

For a general introduction to the effects of room acoustics on the sound of a loudspeaker, please read [Appendix 3: The Influence of Listening Room Acoustics on Loudspeakers](#)

It should be noted that the acoustical behaviour of a room can change considerably when windows or doors are opened and closed. Consequently, for optimal tuning, it is recommended that ARC profiles be made for these cases, particularly if this change is made often (e.g. patio doors).

5.6.1 Creating a new ARC Zone

A new Active Room Compensation zone can be created by pressing the "+" icon in the Room Compensation Edit menu. (Enter the Room Compensation Edit menu by pressing the three dots at the top right of the Room Compensation Select menu.)

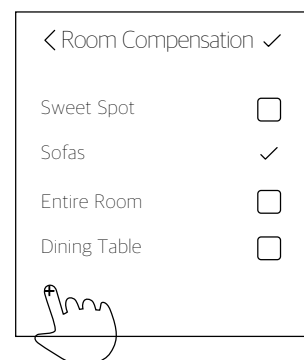

Figure 5.30: Press the "+" icon in the Room Compensation Edit menu to create a new ARC zone.

This will start a procedure where you will be guided through the process of positioning the microphone in different locations to optimised the ARC filters. Each ARC is created using measurements made in three microphone locations, and a maximum of 5 different ARC Zones can be measured.

For additional guidance, please see [Appendix 5: Microphone placement strategy when creating ARC Zones](#).

5.6.2 Selecting an ARC Zone

It is possible to create up to 5 different Active Room Compensation Zones that can be recalled either manually, or automatically as part of a Preset.

In order to disable the active room compensation filters, de-select them in the menu.

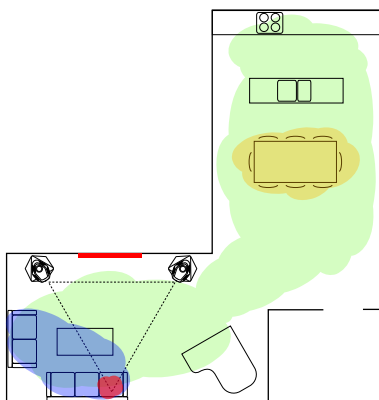

Figure 5.31: An example of a listening space showing four different overlapping ARC zones in red, blue, green, and yellow.

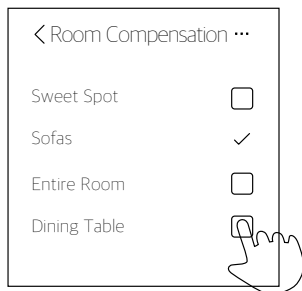

Figure 5.32: Selecting one or more Active Room Compensation zones according to your listening area(s) in the room. It is possible to select more than one zone simultaneously to create a single ARC filter.

5.6.3 Combining ARC Zones

Up to three ARC Zones can be selected simultaneously to create a filter that incorporates the measurements from the applicable areas of the listening room.

Note, however, that adding an extra zone to a current one may compromise the quality of the audio signal in the original zone. For example, if you have two ARC Zones, one for the "Sweet Spot" and the other for the "Dining Table", adding the Dining Table zone to the Sweet Spot zone will reduce the quality of the ARC filtering in the sweet spot location. This is due to the fact that some of the filtering required to compensate for the room's acoustical effects in the dining area may not be required in the sweet spot.

Changing or adding Room Compensation zones will cause a break in the audio signal as the Beolab 90 calculates and updates the appropriate filters. This is normal.

5.7 Volume

The volume of the Beolab 90 is controllable from 0 to 90 in steps of 1 dB. Note that Volume Step 0 is a full mute.

In its default settings, Beolab 90 has been calibrated to match the level of other Bang & Olufsen loudspeakers for

its Power Link and Wireless Power Link inputs. Tables 8.1 and 8.3 show the output level of the loudspeaker for various inputs and parameters.

The Volume control of the Beolab 90 is disabled¹ for Power Link and Wireless Power Link sources. This restriction is made to prevent incorrect calibration of levels in surround sound configurations.

If you manually switch from Power Link to another input while playing signals on both inputs, the volume will automatically reset to the Startup Volume (see Section 7.0.2).

5.8 Mute

Pressing the mute button in the centre of the volume wheel reduces the volume to a fixed value of 0.

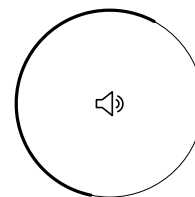

Figure 5.33: The Volume control (the exterior circle) and the Mute control (the icon in the centre of the circle).

In order to unmute the sound, either press the mute button again, or adjust the volume.

If the volume setting of the Beolab 90 was higher than the startup volume when muted, then the volume setting after unmuting will be the same as the startup volume.

5.9 Tone Controls

The Tone Controls on the Beolab 90 consist of traditional Treble and Bass controls. These are global adjustments that are applied to all Presets and to both loudspeakers simultaneously.

¹In fact, it is fixed at maximum: volume step 90

5.9.1 Treble

The Treble adjustment allows you to change the relative amount of high-frequency sound globally using a high shelving filter with a fixed turnover frequency of 8 kHz and a Q of 0.707. The gain at the turnover frequency is one half the maximum gain applied by the filter in decibels. For example, when the gain of the controller is -4 dB, the gain at 8 kHz is -2 dB.

The Treble control is applied to a global filter and therefore is applied to all Presets. It is also independent of the settings of other equalisation controllers in the system such as the Parametric Equaliser controls. The range of the controller is from -6.0 dB to +6.0 dB in steps of 0.5 dB.

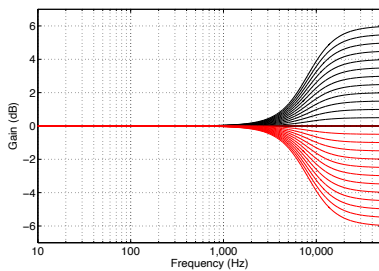

Figure 5.34: Magnitude Responses, Treble controller. Note that this filter is applied to both loudspeakers simultaneously.

5.9.2 Bass

The Bass adjustment allows you to change the relative amount of low-frequency sound globally using a low shelving filter with a fixed turnover frequency of 120 Hz and a Q of 0.707. The gain at the turnover frequency is one half the maximum change in gain applied by the filter in decibels. For example, when the gain of the controller is +6 dB, the gain at 120 Hz is +3 dB.

The Bass control is a global filter and therefore is applied to all Presets. It is also independent of the settings of other equalisation controllers in the system such as the Parametric

Equaliser controls. The range of the controller is from -6.0 dB to +6.0 dB in steps of 0.5 dB.

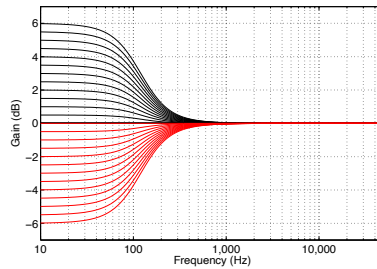

Figure 5.35: Magnitude Responses: Bass controller. Note that this filter is applied to both loudspeakers simultaneously.

5.10 Advanced Controls

The Advanced Controls section gives the user an almost-surgical control over the timbral characteristics of the Beolab 90 using standard equalisation tools found in professional studio equipment and proprietary processing available only in this loudspeaker.

The Advanced Controls of the Beolab 90 are

- **Latency Mode**
- **Parametric Equaliser**

5.10.1 Latency Mode

In order to control the Beam Width of the sound radiating from the Beolab 90, a customised Finite Impulse Response (FIR) audio filter is selected for each woofer, midrange and tweeter. These filters are applied to each of the DSP's 18 audio output channels. However, in order to control the very low frequency bands, it is necessary for the woofers' FIR filters to be very long. One implication of this is that it takes some time between the moment an audio signal enters the input of the loudspeaker and the moment it exits the loudspeaker as sound. The lower in frequency the Beam Width Control is extended, the longer the *latency* (or delay) of the loudspeaker.

This ultimately means that there is a direct relationship between the overall latency of the loudspeaker and its sound characteristics, especially in the low frequency bands. One example of this effect is: the longer the latency, the "tighter" the bass.

However, this may mean that, for some sources and program materials, there is a loss of synchronisation. For example, in its longest latency setting, the loudspeaker may be too late to maintain lip synch with some third-party televisions or some multiroom systems. This is why the latency of the loudspeaker is user-selectable between two different settings.

Auto

If you are using Beolab 90s with a current Beovision television², then the Latency Mode should be set to "Auto". This will allow the television to manage the latency mode of the loudspeakers automatically.

Note that, if the Latency Mode is set to "Auto" and the input is neither Power Link nor Wireless Power Link, then the Beolab 90 will default to a High Latency Mode.

High

To achieve the highest possible level of audio quality from the Beolab 90, the internal digital processing requires one-tenth of a second in order to control the low-frequency behaviour of the system. This is selected by setting the Latency Mode to "High", thus delivering the ultimate possible sound quality from the loudspeaker.

However, there are cases where such a long delay in the loudspeaker will result in loss of synchronisation with other devices in the system such as the video (lip synch) or other loudspeakers in a surround system. If you are experiencing such problems, then the low latency mode should be selected.

²Beoplay V1, Beovision 11, Avant, Avant NG, 14, Horizon, Eclipse, Harmony, or later

The latency of the Beolab 90 in “High” latency mode measured using an analogue input is 100 ms.

Low

In some cases, a Beolab 90 is connected to a system that requires a lower latency. One example of this is a case where the loudspeaker is connected to a non-B&O television or surround processor. Another example is a non-B&O multiroom system that lacks the ability to adapt to different loudspeaker latencies throughout the network.

In this case, the overall delay of the Beolab 90 should be set to “Low” to ensure synchronisation with other loudspeakers in the system.

The latency of the Beolab 90 in “Low” latency mode measured using an analogue input is 25 ms.

Effects of Latency Mode on Beam Width

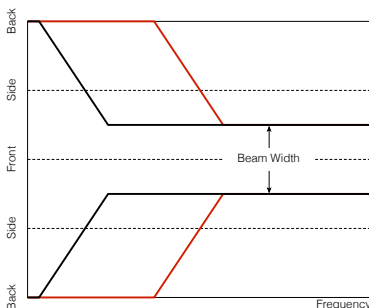

Figure 5.36: Conceptual plot showing the relationship between Latency Mode and a Narrow Beam Width over frequency. The black curve shows a High latency mode. The red curve shows a low latency mode. The high frequency beam width is the same for both latency modes. Only the beam width of the low frequency bands widen for lower latencies.

5.10.2 Parametric Equaliser

For a general introduction to equalisation, please see [Appendix 2: Introduction to Parametric Equalisers](#).

In cases where a more detailed control

of the frequency response of the loudspeaker is needed, a 10-band parametric equaliser is provided. This allows you to sculpt the timbral balance of the loudspeaker with a high degree of precision.

When the gains of all ten filters in the Parametric Equaliser are set to 0 dB, the processing block is automatically disabled.

Figure 5.37 is given as a rough “map” of frequency as reference when using the Parametric Equaliser. Additional guidance is given in Table 8.5 on page 31

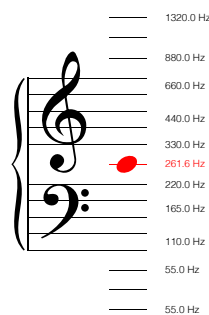

Figure 5.37: Pitch vs. Fundamental frequency for reference purposes when equalising.

The Parametric EQ consists of one low-shelving filter, one high-shelving filter, and 8 reciprocal peak-dip (or peaking) filters, each with a variable Frequency, Gain, and Q.

The filters’ frequency ranges are listed in Table 8.4 on page 31 and their resolution is limited to ISO 1/6th octave centres.

The available Q’s of the filters are limited to the values listed in Table 8.6 on page 31.

Note that all filters are implemented in series, and that frequencies may be overlapped in cases where additional gain is desired.

All filters in the Parametric EQ section are implemented as minimum phase filters.

In order to ensure phase matching of the two loudspeakers and therefore to maintain phantom imaging

characteristics, identical Parametric Equaliser parameters are applied to both loudspeakers simultaneously.

Magnitude Response Plots

Low-Shelving Filter

The Parametric Equaliser has one low-shelving filter available with a frequency range of 32.0 Hz to 500.0 Hz and a Q range of 0.4 to 1. The gain ranges from -6.0 dB to +6.0 dB in steps of 0.5 dB.

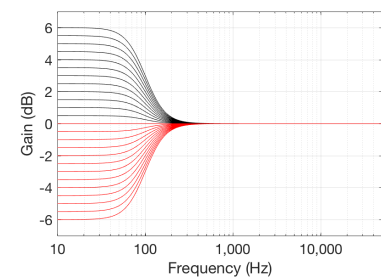

Figure 5.38: Magnitude Responses, low-shelving filter: $F_c = 100$ Hz, Gain varied from -6.0 to +6.0 dB, $Q = 0.7$.

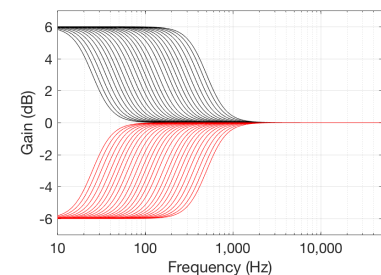

Figure 5.39: Magnitude Responses, low-shelving filter: F_c varied from 32 Hz to 500 Hz., Gain = ± 6 dB, $Q = 0.7$.

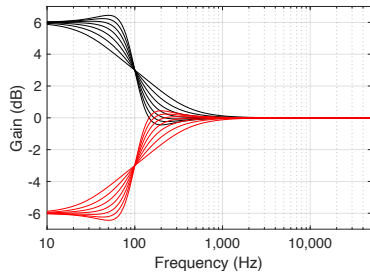

Figure 5.40: Magnitude Responses, low-shelving filter: $F_c = 100$ Hz, Gain = ± 6 dB, Q varied from 0.4 to 1. Note that, for Q values greater than 0.7, there is an overshoot in the magnitude response. For a monotonically increasing (or decreasing) response, the Q should not be set to a value greater than 0.7.

Peaking Filters

The Parametric Equaliser has eight reciprocal peak-dip (or “peaking”) filters available. All peaking filters have a Q value that ranges from 0.5 to 8.0 where the Q is based on a bandwidth defined by the half-gain points³. The gain ranges from -6.0 dB to +6.0 dB in steps of 0.5 dB. The peaking filters have a range of 5 octaves with differing limits as follows:

- Four low-frequency filters with a range of 25.0 Hz to 400.0 Hz.
- Three mid-frequency filters with a range of 250.0 Hz to 4.0 kHz.
- One high-frequency filter with a range of 2.5 kHz to 40.0 kHz.

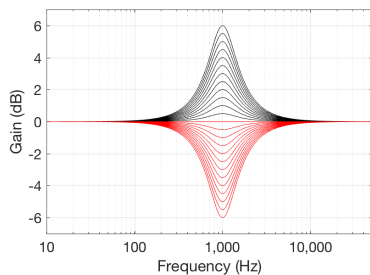

Figure 5.41: Magnitude Responses, Peaking filter: $F_c = 100$ Hz, Gain varied from -6.0 to +6.0 dB, $Q = 1$.

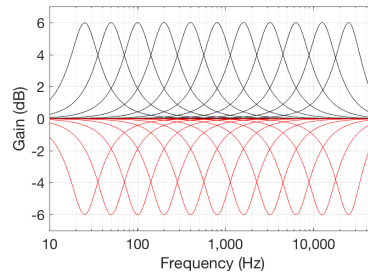

Figure 5.42: Magnitude Responses, Peaking filters: Examples of F_c varied from 25 Hz to 25 kHz on one-octave centres, Gain = ± 6 dB, $Q = 1$.

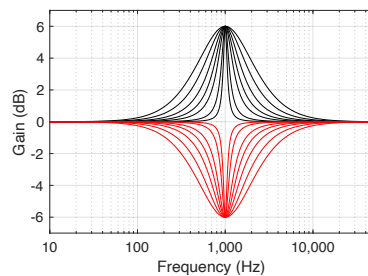

Figure 5.43: Magnitude Responses, Peaking filters: $F_c = 100$ Hz, Gain = ± 6 dB, Q varied from 0.3 to 8.

High-shelving Filter

The Parametric Equaliser has one high-shelving filter available with a frequency range of 1.0 kHz to 16.0 kHz and a Q range of 0.4 to 1. The gain ranges from -6.0 dB to +6.0 dB in steps of 0.5 dB.

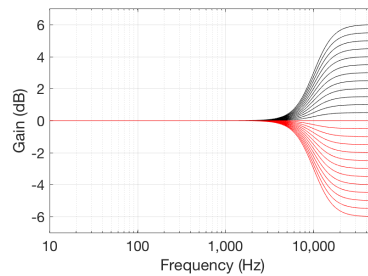

Figure 5.44: Magnitude Responses, high-shelving filter: $F_c = 10$ kHz, Gain varied from -6.0 to +6.0 dB, $Q = 0.7$. Note that this filter is applied to both loudspeakers simultaneously.

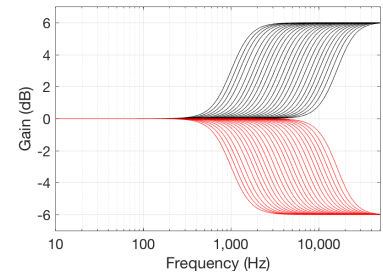

Figure 5.45: Magnitude Responses, high-shelving filter: F_c varied from 1 kHz to 16 kHz, Gain = ± 6 dB, $Q = 0.7$.

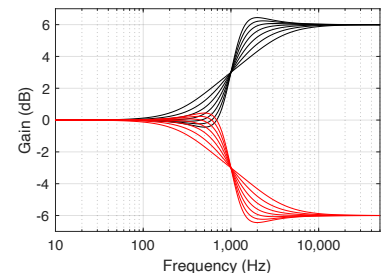

Figure 5.46: Magnitude Responses, high-shelving filter: $F_c = 100$ Hz, Gain = ± 6 dB, Q varied from 0.4 to 1. Note that, for Q values greater than 0.7, there is an overshoot in the magnitude response. For a monotonically increasing (or decreasing) response, the Q should not be set to a value greater than 0.7.

General comment regarding equalisation

Although it is possible to apply a gain to the signal using the parametric equaliser, this will have implications on the headroom of the total system. For example, if you set the gain of an equaliser to be +6 dB at 30 Hz, and play a signal that contains a 30 Hz tone at maximum level (e.g. 0 dB FS on a digital input) then you will reach the maximum possible output of the loudspeaker (and therefore the ABL algorithm will start to protect the loudspeaker) at a volume step that is 6 dB lower than it would be without the filter.

This is the reason that a “rule of thumb” for professional audio engineers is that, when adjusting parameters in a parametric equaliser, whenever possible, a “cut” is preferable to a “boost”. For example, if

³For more information on this, please see “The Equivalence of Various Methods of Computing Biquad Coefficients for Audio Parametric Equalizers” Robert Bristow-Johnson, Preprint 3906, 97th International Convention of the Audio Engineering Society, November 1994

you wish to have more bass, it is smarter to reduce the treble and turn up the overall volume than to simply increase the bass. The result will be the same at lower volume settings, but there can be a remarkable difference at higher listening levels.

5.11 Automating Preset Selection

It is not necessary to select Presets manually. Instead, it is possible to have Presets triggered to be selected automatically using one of two possible external controls: **By Speaker Group** (if you have a Bang & Olufsen television) or **By Source**.

By Speaker Group

If you have a pair of Beolab 90s connected to a Bang & Olufsen television as shown in Figure 5.47, then it is possible to automatically trigger presets in tandem with the television's Speaker Group. This selection is done in the Speaker Group menus on the television, where you can select the "Speaker Preset" number for the Beolab 90 as one of the parameters in

the Speaker Group. See the Beovision Technical Audio Guide for more information.

Note that, in cases where a multichannel loudspeaker configuration includes more than one pair of Beolab 90s or Beolab 50s connected to a Beovision television, it will be necessary to ensure that the Preset *numbers* are the same for all pairs of Beolab 90s in the system, since the television sends out only one Speaker Preset number for all loudspeakers connected to it.

By Source

Imagine you have a pair of Beolab 90s connected to two non-B&O sources as shown in Figure 5.49.

- an AV Surround Processor connected to the XLR Line inputs. The device is also connected to other loudspeakers to form a multichannel (surround) configuration for watching movies.
- a high-resolution audio player connected to the S/PDIF input.

In addition, you have configured two

Presets in your Beolab 90s:

1. Optimised for multichannel listening with a listening zone that encompasses more than one listening position (e.g. the whole sofa).
2. Optimised for 2.0 Stereo listening with only one "sweet spot" in the centre of the sofa.

In this situation, you want the AV Surround processor to automatically enable Preset 1 and the high-resolution audio player to automatically enable Preset 2. In this way, there is no need to manually change Beolab 90 presets. See Section 6.2.1 for more information.

Mixed systems

It is possible to trigger both by source and by Speaker Group in mixed systems such as that shown in Figure 5.48. In this case, the Beovision television is controlling the Beolab 90 preset within its Speaker Group parameters. However, the Beolab 90 can also have a preset that is automatically triggered by the audio player connected via S/PDIF.

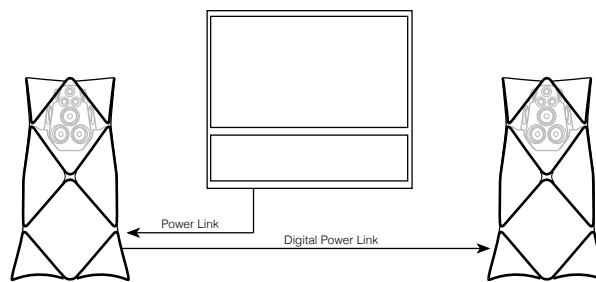

Figure 5.47: An example of a pair of Beolab 90s connected to a Beovision 11 using Power Link.

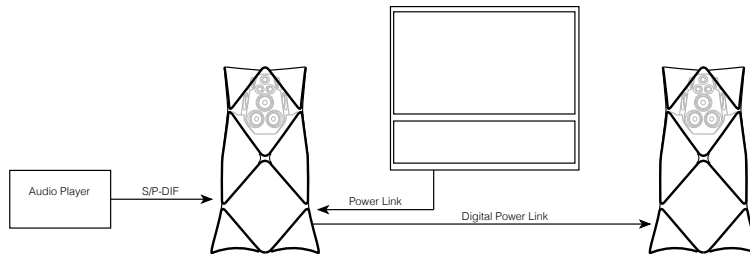

Figure 5.48: An example of a pair of BeoLab 90s connected to one B&O source using Power Link and a third-party audio player using S/PDIF.

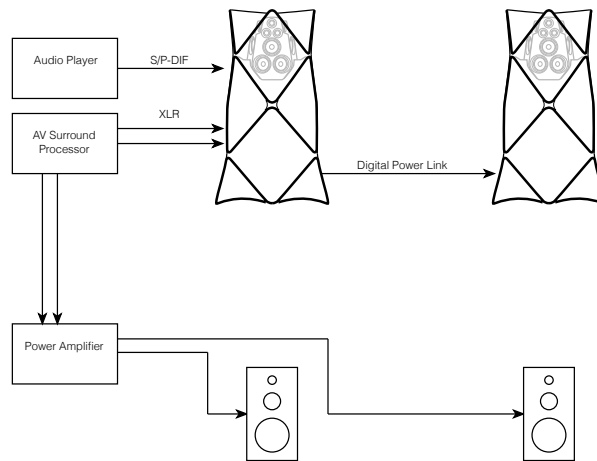

Figure 5.49: An example of a pair of BeoLab 90s connected to two third-party sources: an AV Surround Processor using XLR and a separate audio player using S/PDIF. Note that, in this case, the latency of the BeoLab 90s must be carefully managed in the setup of the loudspeakers and the AV Surround Processor in order to ensure that the multichannel system is behaving correctly.

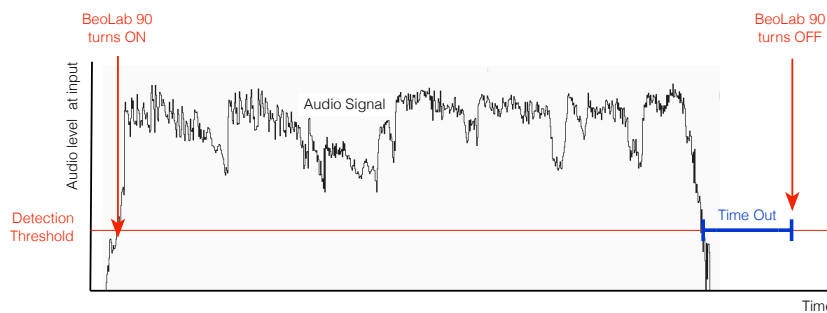

Figure 5.50: The "Detection Threshold" and "Time Out" parameters

Inputs

As can be seen on the connector panel shown in Figure 6.2, the Beolab 90 has a total of eight different audio inputs as follows:

Bang & Olufsen Proprietary

- Power Link (analogue)
- Wireless Power Link (digital)

Digital inputs

- S/PDIF (or “coaxial”)
- Optical
- USB Audio

Analogue inputs

- XLR (or “balanced line”)
- RCA Phono (or “unbalanced line”)

Wireless inputs

- WiSA

The technical specifications for these can be found in [Inputs](#) on page 34.

6.1 Inputs Selection

6.1.1 Automatic Selection

Selection Priority

If the Beolab 90 is set to automatically detect an input signal, then it may be necessary to customise the prioritisation of the sources. For example, if you have a CD player connected to the S/PDIF input and a turntable connected to the XLR input, and both sources are playing, this parameter allows you to determine which source should “win” and be played by the Beolab 90.

This prioritisation can be personalised by changing the vertical order of the inputs on Beolab 90 interface in the Input Select menu (press the “...” icon at the top right to enter the edit mode).

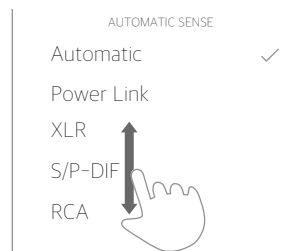

Figure 6.1: The priority of automatically-selected sources can be changed by re-arranging their order.

6.1.2 Manual Selection

It is possible to manually select inputs without the smartphone interface using the BeoRemote 1 remote control. For a description of how to do this, including instructions on setting up the BeoRemote 1, please see [Section 21](#) on page 62.

6.2 Individual Input Parameters

Note that not all controls are available for all inputs.

6.2.1 Automatic Preset Selection

Each input (apart from the Power Link and Wireless Power Link inputs) can be set to automatically enable a Speaker Preset. This selection is made in the menu for the individual input.

When the Preset is set to 0, then no change will be made to the current preset when the source is selected.

6.2.2 Detection Threshold

The Beolab 90 can be set to automatically turn itself on by detecting the presence of a signal on the XLR and RCA line inputs. However, depending on your source and/or the style of music you typically listen to, it

may be necessary to make the detection more or less sensitive. This can be adjusted using the *Detection Threshold* control.

For example, if you listen to music with a large dynamic range, it may be necessary to lower the Detection Threshold to make the Beolab 90 more sensitive to the presence of quiet signals. Conversely, if you have an audio source that has a higher noise floor, it may be necessary to increase the Detection Threshold in order to make the Beolab 90 less sensitive.

| | |
|-----------------|----------------|
| Range | -76 to -46 dBV |
| Resolution | 3 dB |
| Factory Default | -76 dBV |

See [Figure 5.50](#) for a graphic representation of the the detection threshold relative to the signal strength.

The Detection Threshold parameter is not available for the Power Link input, since the loudspeaker is turned on and off automatically by the Power Link source.

6.2.3 Maximum Input Voltage

Different audio sources have different maximum analogue output levels. Typically, a maximum level from a line-level RCA output is 2.0 V RMS, however, different manufacturers occasionally choose to deliver a higher output level on some models.

In order to maximise the signal-to-noise ratio of your audio system, the Beolab 90 gives you the option to change the Maximum Input Voltage for the the XLR and RCA line inputs. The datasheet for your audio source should indicate its maximum output level. The value in the Beolab 90 interface should be set to match this value.

If the source has a higher maximum output level than that which is set in the Beolab 90 interface, this may

¹An analogue sine wave with an electrical level equal to the setting of the Maximum input Voltage will produce an internal digital level of 0 dB FS at the output of the ADC.

cause distortion due to clipping of the signal at the loudspeaker's inputs.¹

If the source has a lower maximum output level than that which is set in the Beolab 90 interface, this will cause your maximum output of the loudspeaker to be lower, and the output noise floor to be increased.

Options 2.0, 4.0, 6.5 V RMS
 Factory Default 2.0 V RMS

The Maximum Input Voltage parameter is only available for the XLR and RCA line inputs.

6.2.4 Time-out

In cases where the automatic signal detection is used to turn the on Beolab 90, the *Time Out* control can be used to determine the length of time the loudspeaker continues to be powered up after the audio signal has stopped.

It may be necessary to increase the length of this time if you listen to music with an extreme dynamic range. For example, a quiet passage in a piece of music may be below the detection threshold. If the duration of that passage is longer than the *Time Out* value, then the loudspeaker will go into standby mode while the piece is playing. See Figure 5.50 for a visual example of the Detection Threshold and Time-out parameters.

Options 0 - 840 seconds

The Time-out function is not available for the Power Link, Wireless Power Link and WiSA inputs.

6.2.5 Input Impedance

If the Beolab 90's RCA Line inputs are connected to a device's headphone output that uses a Class-D amplifier, there may be instances where this causes the noise floor to rise audibly.

This is caused by the input impedance of the Beolab 90 being much higher than that which is expected by the headphone amplifier's designer. In order to correct this problem, the input impedance of the RCA input can be set to a low value of 50 Ω.

However, if the input impedance of the RCA input is set to 50 Ω and it is connected to a device's standard low-impedance line output, this may have a detrimental effect on the signal. For example, the maximum possible output level will be reduced. In some cases, incorrectly setting the input impedance to 50 Ω may also cause distortion of the audio signal.

Options 50 Ω, 50 kΩ
 Factory Default 50 kΩ

The Input Impedance control is only available for the RCA line input.

6.2.6 Control Presets using Speaker Groups

In cases where the Beolab 50 is connected to a Bang & Olufsen television such as a Beovision Avant, it may be desirable to automate changes of Preset to coincide with changes in Speaker Group on the television.

Please consult the Technical Sound Guide for your television for further details on how to program it to trigger the desired Beolab 90 Preset to accompany a specific Speaker Group.

The this parameter is only applicable to the Power Link and Wireless Power Link inputs. It is also only applicable to systems containing a Bang & Olufsen television that has the Speaker Group option in its software.

6.3 Connection Panels

The connection panels on the Primary and Secondary Beolab 90s are slightly

different in that audio signals can only be connected to the Primary loudspeaker. The audio signal connections from your source devices should be connected to the Primary loudspeaker. The only audio input on the Secondary loudspeaker is the DPL or Digital Power Link input.

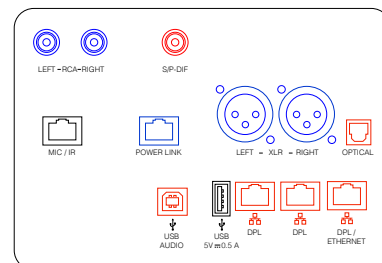

Figure 6.2: Audio connection panel – Primary loudspeaker. Analogue inputs are shown in blue. Digital audio connections are shown in red. Utility connections are shown in black.

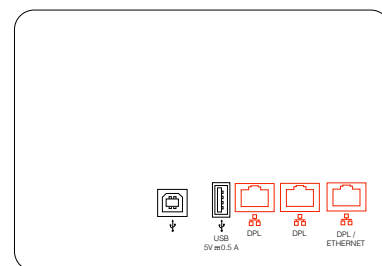

Figure 6.3: Audio connection panel – Secondary loudspeaker. The only audio connectors on this loudspeaker are for the Digital Power Link connection to the Primary loudspeaker.

If you are familiar with XLR connectors, you will notice that the push-button lock is missing on the XLR input. This is intentional and has been done to help to minimise rattling artefacts when playing at higher sound pressure levels.

For specific information regarding the various inputs, please see [Inputs](#) on page 34.

System

7.0.1 Max Volume

The *Max Volume* control allows you to determine the limit of the volume control.

| | |
|-----------------|--------|
| Range | 0 - 90 |
| Resolution | 1 dB |
| Factory Default | 90 |

The *Max Volume* parameter is not available for the Power Link and Wireless Power Link inputs.

7.0.2 Startup Volume

The *Startup Volume* control allows you to determine the volume level when

the Beolab 90 wakes as a result of a detected signal or a change in source.

| | |
|-----------------|--------|
| Range | 0 - 60 |
| Resolution | 1 dB |
| Factory Default | 42 |

The *Startup Volume* parameter is not available for the Power Link and Wireless Power Link inputs.

Tables

8.1 Loudspeaker Sensitivity

| Input | “Max Input” Level Setting | dB SPL |
|------------|---------------------------|--------|
| Power Link | 6.5 V rms (Fixed) | 88.0 |
| XLR, RCA | 6.5 V rms | 88.0 |
| XLR, RCA | 4.0 V rms | 92.2 |
| XLR, RCA | 2.0 V rms | 98.2 |

Table 8.1: Unweighted Sound Pressure Level (SPL) of the Beolab 90 at 1 m in a free field (200 Hz – 2 kHz). Input signal strength: 125 mV rms. Volume Step: 90. All other parameters set to Factory Defaults. The input signal strength on the XLR input is measured between pins 2 and 3.

| Input | Output |
|----------------------------|-------------|
| USB Audio, S/PDIF, Optical | 92.3 dB SPL |
| Wireless Power Link | 92.3 dB SPL |

Table 8.2: Unweighted Sound Pressure Level (SPL) of the Beolab 90 at 1 m in a free field (200 Hz – 2 kHz). Input signal: -30.0 dB FS. Volume Step: 90. All other parameters set to Factory Defaults.

8.2 Volume Control

| Volume Step | Output |
|-------------|-------------|
| 90 | 92.3 dB SPL |
| 89 | 91.3 dB SPL |
| 88 | 90.3 dB SPL |
| . | . |
| 51 | 53.3 dB SPL |
| 50 | 52.3 dB SPL |
| 49 | 51.3 dB SPL |
| . | . |
| 2 | 4.3 dB SPL |
| 1 | 3.3 dB SPL |
| 0 | -∞ dB SPL |

Table 8.3: Unweighted Sound Pressure Level (SPL) of the audio signal from a Beolab 90 at 1 m in a free field (200 Hz – 2 kHz). Input signal: -30.0 dB FS. Note that these values consider only the output level of the input audio signal and assume that thermal protection has not been engaged.

8.3 Parametric Equaliser

| Type | Range (Hz) | Filters |
|---------------|----------------|---------|
| Low-shelving | 32.0 – 500.0 | 1 |
| Peaking (LF) | 25.0 – 400.0 | 4 |
| Peaking (MF) | 250.0 – 4.0 k | 3 |
| Peaking (HF) | 2.5 k – 40.0 k | 1 |
| High-shelving | 1.0 k – 16.0 k | 1 |

Table 8.4: Frequency ranges of Parametric EQ filters. The filter frequencies are ISO 1/6-octave spacing.

| Band | Frequency (Hz) |
|------------|----------------------|
| Ultrasonic | 22.4 kHz to 40.0 kHz |
| Treble | 4 kHz to 20 kHz |
| Midrange | 125 Hz to 3.55k |
| Bass | 25 Hz to 112 Hz |

Table 8.5: Frequency Bands for approximate information only.

| Filter Type | Q values |
|---------------|-----------------------------------|
| Low-shelving | 0.4, 0.5, 0.6, 0.7, 0.8, 0.9, 1.0 |
| Peaking | 0.5, 0.7, 1.0, 1.4, 2.0, 4.0, 8.0 |
| High-shelving | 0.4, 0.5, 0.6, 0.7, 0.8, 0.9, 1.0 |

Table 8.6: Available Q values of Parametric EQ filters.

Features

9.1 Resonance-based Sound Design

A very large part of the sound tuning of the Beolab 90, like many other Bang & Olufsen loudspeakers, is based on acoustical measurements performed at many locations around, above and below the loudspeaker.



Figure 9.1: The first Beolab 90 prototype undergoing acoustical measurements in The Cube.

One of the important aspects of these measurements is to find the behaviour of the loudspeaker in time. For example, if a sound is sent to the loudspeaker, and then stopped suddenly, does the loudspeaker also stop, or does it “ring” at some frequencies (in exactly the same way that a bell rings when struck). Ringing in the time response of a loudspeaker is an indication that it has a resonance: a frequency at which it “wants” to move. This resonance has a detrimental effect on the overall sound of the loudspeaker, since it “smears” sounds in time.

For example, if you have a loudspeaker that has a natural resonance at 110 Hz (two octaves below a “Concert A”, to musicians) then it will naturally ring at

that note when it is “hit” with an impulsive signal such as a kick drum. If the song that the band is playing is not in A (major or minor), but in B-Flat instead, then there will be a dissonance between the notes played most often in the song, and the note that is “singing along” with the kick drum. This can contribute to the loudspeaker sounding “muddy” or “boxy” (to use only two words...).

This is why the measurement-based portion of the filtering of all current Bang & Olufsen active loudspeakers is primarily designed to counteract the natural resonances in the system. So, for example, if one of the woofers in the Beolab 90 has a natural resonance at 110 Hz, then that resonance is mirrored with an equal, but opposite phase behaviour in the Digital Signal Processing engine. The total result of the filter in the DSP and the behaviour of the woofer is that there is no unwanted ringing in the entire system. This, in turn, means that the loudspeaker’s response is controlled in the time domain and therefore also in the frequency domain as well.

This is only possible with an extensive set of measurements of each loudspeaker driver’s mechanical and acoustical behaviour and a custom-created set of filters for it.

9.2 Phase-Optimised Filtering

In order for the Beolab 90 to deliver its level of sound performance, filters are used in the Digital Signal Processing (DSP). Generally, an audio filter is a device that changes the overall response of the audio signal. In the case of Beolab 90, these are used for various reasons such as controlling the relationship between the different loudspeaker drivers, acting as crossovers to distribute the correct signals to the tweeters, midranges and woofers, and optimising the overall magnitude response of the total

system.

An audio filter has an effect on the behaviour of the signal’s magnitude (how loud it is at a given frequency) and/or its phase. Since the Beolab 90 uses digital instead of analogue filters, we are able to choose the characteristics of each filter’s phase response independently of its magnitude response. For example, a filter can be implemented to have a “minimum phase” or a “linear phase” (the two most common responses) characteristic, regardless of the magnitude response it is required to deliver.

The phase response of each filter in Beolab 90’s processing chain have been individually tailored according to its particular function. For example, some of the crossover filters have been implemented as linear phase filters. Most filters in the Active Room Compensation algorithm are implemented as minimum phase filters because room resonances have a minimum phase characteristic. The Beam Width Control filters have customised phase responses that are dependent on the particular frequency-dependent characteristics of the individual loudspeaker drivers that they control and are therefore neither minimum phase nor linear phase.

9.3 Automatic Bass Linearisation (ABL) and Thermal Protection

Almost all loudspeakers in the Bang & Olufsen portfolio (including Beolab 90) feature Automatic Bass Linearisation or “ABL”. This is an algorithm that was first patented by B&O in 1991 and is custom-tuned for each of our products. Its purpose is to ensure that, when the physical limits of a component of the loudspeaker are reached (for example, a woofer is approaching its maximum excursion or a power amplifier is close to clipping) the loudspeaker prevents

that limit from being reached and the transition to that limit is “softened” (depending on the component in question).

In addition, Beolab 90’s processing continually monitors the individual temperatures of many internal components including:

- Individual loudspeaker driver magnets
- Power Amplifier modules
- DSP circuit boards
- Power Supply circuit boards

Using this information, combined with the power that the amplifiers deliver to the loudspeaker drivers, the temperatures of many more components within Beolab 90 are calculated using customised thermal models of the loudspeaker’s components and construction.

If the temperature of a component inside the loudspeaker approaches its “thermal limit” (the temperature at which it stops working due to overheating) the signal processing of the Beolab 90 adjusts the signals to protect the component. The exact type of adjustment depends on the

particular component that is approaching its limits. As a simple example, if a tweeter voice coil is calculated to be approaching its limit, then its gain is reduced to attempt to protect it from destruction.

It is important to state that this does *not* mean that the Beolab 90 is indestructible – but it does make it more difficult to destroy.

More information can be found in [Appendix 6: ABL - Adaptive Bass Linearisation](#).

9.4 Thermal Compression Compensation

Beolab 90’s processing includes automatic compensation for changes in loudspeaker driver response as a result of internal changes in temperature.

For more an in-depth discussion of this feature, please read [Appendix 7: Thermal Compression Compensation](#).

9.5 Production “Cloning”

Every Beolab 90 that leaves the production line is measured in a

custom-built anechoic chamber to ensure that its performance matches a “Golden Reference” loudspeaker. This automated measurement is performed using 18 microphones (one for each loudspeaker driver) where small differences in the responses are found and custom correction filters are created and loaded into the Digital Signal Processing. This ensures that each loudspeaker’s third-octave smoothed response matches that of the Golden Reference loudspeaker within 0.2 dB between 20 Hz and 20 kHz.

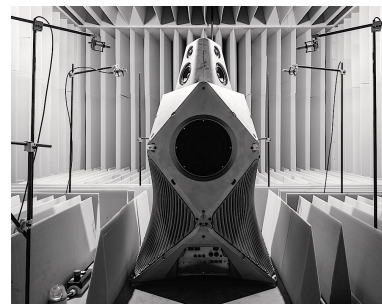

Figure 9.2: An early prototype in the anechoic chamber at the end of the Beolab 90 production line where every loudspeaker is measured and calibrated.

Technical Specifications

10.1 Total System

Note: Total System measurements performed with Sound Design set to "Flat on-axis" and Active Room Compensation disabled.

| | |
|--------------------|---|
| Frequency Response | 25.2 Hz to 28.1 kHz (± 1 dB, 1/3 octave smoothed) |
| Frequency Range | < 12 Hz to > 43 kHz (-10 dB, ref. 200 Hz - 2 kHz, unsmoothed) |
| Peak SPL | 123 dB SPL (unweighted) @ 1 m, on-axis in a free field |
| Sensitivity | see Section 8.1 |

10.2 Preamplifier and Processor Section

In order to simplify comparison of Beolab 90's technical data to other products, the information in this chapter has been divided into three sections:

- *Preamplifier and Processor*, equivalent to a surround processor, preamp or receiver
- *Power Amplifiers*
- *Loudspeaker Drivers*

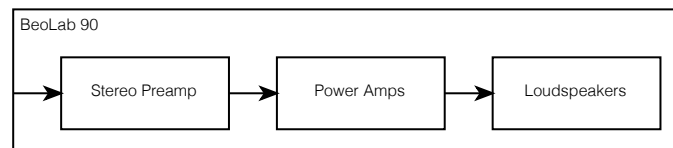

Figure 10.1: A block diagram of the Beolab 90 showing the comparative sections in terms of competing devices.

10.2.1 Overall Specifications

Note: Hardware-only measurement. All filters and equalisation bypassed or removed from signal processing for measurements.

Digital input to DAC outputs

| | |
|--------------------|---|
| Frequency Response | 0 Hz to 40 kHz (+ 0 dB, -1 dB) |
| Frequency Range | 0 Hz to 75 kHz (+ 0 dB, -3 dB) |
| THD+N | 0.004% (997 Hz, -1 dB FS, 22 Hz - 20 kHz) |
| Dynamic Range | 122 dB (A) (997 Hz, -60 dB FS, 20Hz - 20kHz, AES17) |

10.2.2 Inputs

Analogue Inputs

Analogue-to-Digital Converter

The same ADC model is used for all analogue inputs.

| | |
|----------------------------|---|
| Model | Texas Instruments PCM4220 |
| Sampling Rate | 192 kHz (fixed) |
| Resolution | 24 bits |
| Frequency Response | 10 Hz - 80 kHz (+ 0 dB, -0.2 dB) |
| Frequency Range | < 2 Hz - 85 kHz (-3 dB) |
| Dynamic Range (Typical) | 122 dB (A) (997 Hz, -60 dB FS) |
| Dynamic Range (Worst-case) | 117 dB (A) (997 Hz, -60 dB FS) |
| THD+N | 0.001% (997 Hz, -1 dB FS, 22 Hz - 20 kHz) |
| Channel Separation | 100 dB (20 Hz to 20 kHz) |
| Passband Ripple | ±0.001 dB |

Power Link

| | |
|-----------------------|---|
| Connector | RJ45 |
| Input Impedance | 100 k Ω |
| Audio Channels | 2 |
| Maximum Input Voltage | 6.5 V RMS |
| Features | 5 V control voltage for On/Standby Power Link Data support |
| Sensitivity | 125 mV RMS produces 88 dB SPL (1 m, on-axis, free-field) |

XLR Line

| | |
|--------------------------------|-------------------------------------|
| Input Impedance (Single-ended) | 50 k Ω (Fixed) |
| Input Impedance (Balanced) | 100 k Ω (Fixed) |
| Maximum Input Voltage | 2.0, 4.0, 6.5 V RMS (Selectable) |
| Features | Differential and impedance balanced |

Pin configuration

| | |
|-------|--------------------------------|
| Pin 1 | Audio ground |
| Pin 2 | Positive signal input ("hot") |
| Pin 3 | Negative signal input ("cold") |

The XLR connector casing (or "shell") is connected to the chassis ground of the Beolab 90 for shielding. Internally, the shield and the audio ground (Pin 1) of the XLR inputs are connected using a "star ground" topology.

RCA Line

| | |
|-----------------------|--|
| Input Impedance | 50 Ω , 50 k Ω (Selectable) |
| Maximum Input Voltage | 2.0, 4.0, 6.5 V RMS (Selectable) |

Digital Inputs

Sampling Rate Converter

The SRC is applied to all digital inputs.

| | |
|----------------------|--|
| Model | Texas Instruments SRC4392 |
| Output sampling rate | 192 kHz (fixed) |
| Output word length | 24 bits |
| THD+N | 0.000014% (f=997 Hz, 0 dBFS, 22 Hz - 40 kHz, unweighted) |
| Dynamic Range | 138 dB (f=997 Hz, -60 dBFS, 22 Hz - 40 kHz, unweighted) |
| Passband Ripple | ±0.008 dB |

S/PDIF

| | |
|------------------|---------------------------------------|
| Supported Format | Linear PCM |
| Sampling rate | Standard sampling rates up to 192 kHz |
| Word length | 24 bits |

Optical Connector

| | |
|------------------|--|
| Supported Format | Linear PCM |
| Sampling rate | Standard sampling rates up to and including 96 kHz |
| Word length | 24 bits |

USB Audio Connector

| | |
|------------------|---|
| Supported Format | Linear PCM |
| Sampling rate | Standard sampling rates up to and including 192 kHz |
| Word length | 24 bits |

Wireless Power Link

| | |
|------------------|--|
| Supported Format | Linear PCM |
| Sampling rate | Bang & Olufsen Wireless Power Link is set to run at 48 kHz |
| Word length | 24 bits |

WiSA

| | |
|------------------|---|
| Supported Format | Linear PCM |
| Sampling rate | Standard WiSA sampling rates up to and including 96 kHz |
| Word length | 24 bits |

10.2.3 Digital Signal Processor

| | |
|------------------|---------------------------|
| Model | Analog Devices ADSP-21489 |
| Number | 2 |
| Instruction Rate | 400 MHz |
| Sampling rate | 192 kHz (fixed) |
| Notes | 32-bit floating point |

10.2.4 Digital to Analogue Converters

These specifications include the analogue stages that follow the DAC outputs.

| | |
|--------------------|---|
| Model | Texas Instruments / Burr-Brown PCM1798 |
| Audio Channels | 18 |
| Sampling rate | 192 kHz (fixed) |
| Word length | 24 bits |
| Frequency Response | 0 Hz to 40 kHz (+ 0 dB, -1 dB) |
| Frequency Range | 0 Hz to 75 kHz (+ 0 dB, -3 dB) |
| THD+N | 0.004% (997 Hz, -1 dB FS, 22 Hz - 20 kHz) |
| Dynamic Range | 122 dB (A) (997 Hz, -60 dB FS, 20Hz - 20kHz, AES17) |
| Channel Separation | 110 dB (20Hz - 20kHz, AES17) |
| Level Linearity | ±1 dB (at -120 dB FS) |

10.3 Power Amplifiers

10.3.1 Tweeters and Midrange Sections

One amplifier per loudspeaker driver

| | |
|-----------------|---|
| Model | Bang & Olufsen ICEpower AM300-X |
| Peak Voltage | 50 V |
| Peak Current | 20 A |
| Peak Power | 780 W (into 3.2 Ω) |
| Frequency Range | < 2 Hz - > 100 kHz (+0 dB, -3 dB) |
| THD+N | 0.02% (20 Hz - 20 kHz, 100 mW - 300 W, 4 Ω , AES17) |
| Features | DualLoop3 - ICEpower's third-generation Class-D topology Custom-modified for Beolab 90 |

10.3.2 Woofer Section

One amplifier per loudspeaker driver

| | |
|-----------------|---|
| Model | Heliox AM1000-1 |
| Peak Voltage | 100 V (Software-limited, Hardware capable of 150 V) |
| Peak Current | 40 A |
| Peak Power | 3125 W (into 3.2 Ω) |
| Frequency Range | < 1 Hz - > 20 kHz (+0 dB, -3 dB) |
| THD+N | 0.05% (20 Hz - 20 kHz, 100 mW - 1000 W, 4 Ω , AES17) |
| Features | Unified Class-D (UCD) Custom-modified for Beolab 90 |

10.4 Loudspeaker Drivers

10.4.1 Tweeters

| | |
|--------------------|--|
| Model | Scan-Speak Illuminator D3004/602000 |
| Number | 7 |
| Nominal Impedance | 4 Ω |
| Effective Diameter | 30 mm |
| Features | Textile dome diaphragm Symmetrical drive, SD-2 motor Non-resonant aluminium rear chamber |

10.4.2 Midranges

| | |
|--------------------|-------------------------------------|
| Model | Scan-Speak Illuminator 12MU/4731T00 |
| Number | 7 |
| Nominal Impedance | 4 Ω |
| Effective Diameter | 86 mm |
| Features | Under-hung neodymium motor design |

10.4.3 Front Woofer

| | |
|--------------------|---|
| Model | Scan-Speak Revelator 32W/4878T00 |
| Number | 1 |
| Nominal Impedance | 4 Ω |
| Effective Diameter | 260 mm |
| Features | Paper sandwich cone with patented foam filling Symmetrical drive motor |

10.4.4 Woofers

| | |
|--------------------|---|
| Model | Scan-Speak Discovery 26W/4558T00 |
| Number | 3 |
| Nominal Impedance | 4 Ω |
| Effective Diameter | 212 mm |
| Features | Anodised aluminium cone Fibre glass dust cap |

10.5 Power Supply

| | |
|------------------------|--------------------------------|
| Power Consumption | |
| Low-Power Standby | < 0.5 W |
| Network Standby | < 2 W |
| Low-level audio / Idle | Approximately 150 W continuous |
| Sustained Max Average | 250 W |
| Peak | > 18,000 W (Duration < 1 ms) |

10.6 Digital Power Link

| | |
|---------------|--|
| Technology | Audio Video Bridge (AVB) |
| Sampling Rate | 192 kHz (fixed) |
| Bit depth | 24 |
| Features | Includes proprietary B&O data channels for inter-loudspeaker communication |

FAQ

11.1 Multichannel system setup

In cases where you use more than one pair of Beolab 90s in a configuration, there are some recommendations that should be followed in order to facilitate daily use.

11.1.1 Bang & Olufsen television as source

As described in Section 5.11.0.1, a current Bang & Olufsen television can automatically switch Beolab 90 Presets as part of the Speaker Group function. However, it should be noted that a given Speaker Group in the television sends only one Speaker Preset value on its Power Link outputs to all loudspeakers connected to the television. This means that the preset identification numbers in all Beolab 90 and Beolab 50 pairs must match for a given configuration corresponding to a Speaker Group in the television.

11.1.2 Third-party device as source

When using a third-party multichannel device as a source for more than one pair of Beolab 90s, each Primary-Secondary pair of loudspeakers should be configured correctly for a given source. The resulting parameters should be saved to a Preset that is then triggered by the appropriate input. See Section 5.11 on page 26 for more information.

11.2 Does Beolab 90 support DSD?

DSD and DSD over PCM (DoP) are not currently supported by Beolab 90. In order to play DSD audio files, it is therefore necessary to convert to PCM digital or analogue signals *in the audio player* before sending the signals

further to the loudspeakers.

Note that, since the Beolab 90 audio signal path contains a significant amount of digital signal processing (DSP) which is performed on linear PCM signals, a conversion of DSD to PCM is required somewhere in the audio chain. Placing this conversion process ahead of the loudspeakers' inputs gives the user the option to choose his or her preferred filter for the process.

11.3 Does Beolab 90 support DXD?

DXD audio (PCM audio with a sampling rate of 352.8 kHz and 24 bit resolution) is not supported by Beolab 90, since its digital inputs will not accept sampling rates above 216 kHz.

In order to play DXD files on the Beolab 90, the audio signal will either have to be downsampled to a maximum of 192 kHz or converted to analogue in advance of sending the signals to the loudspeakers' inputs.

11.4 Why does the Beolab 90 sound "different" when I switch to watching television?

Some features of the Beolab 90 are disabled when they are connected to current Bang & Olufsen sources. This is to ensure that similar audio processing is not performed twice. There are cases, however, where although two processes are similar, they are not identical. For example, it may be the case that the bass or treble adjustments in the Beolab 90 do not have the same frequency responses as those in the audio source. For more information about this, please see Section 13.1 on page 41.

It may also be the case that the adjustment of some of these processors are different in the

loudspeakers and the source. For example, if the bass is increased in the loudspeakers, and then disabled because the Power Link input is chosen, there will be a resultant change in timbre of the loudspeakers.

There may also be instances where a Bang & Olufsen source automatically changes the latency mode of the Beolab 90s in order to preserve lip sync or synchronisation with multiroom systems. This will also have a potentially audible effect on the audio quality of the loudspeakers.

Setup “Tips and Tricks”

Setting Speaker Levels and Distances

Although it is possible to set Speaker Levels and Distances using measurements, these can, in some cases, be improved by making small final adjustments “by ear” while listening to music instead. While sitting in the preferred location, play a track with a solid centre phantom image (“Tom’s Diner” by Suzanne Vega is a good choice) and fine-tune the Speaker Level and Distance values on one of the two loudspeakers to place the centre image in the correct location. It is recommended that the Speaker Distance value be optimised before the Speaker Level, since it has a larger perceived effect.

ARC vs. Beam Width and Beam Direction

The Active Room Compensation algorithm calculates a custom filter for the Beam Width, Beam Direction, and Latency Mode of the preset. When editing a preset, it is wise to turn off the ARC filters while switching between different Beam Widths, Beam Directions, and Latency Modes in order to avoid waiting for this calculation to be performed. When the appropriate settings have been chosen, then go back to your ARC setup and enable the filters.

iOS settings during setup

In some cases, particularly when making ARC measurements, it may be helpful to change the Settings of your iOS device to ensure that it does not “sleep”, since this can cause it to lose communication with the Beolab 90s

Speaker Distances for larger listening areas

When measuring the Speaker Distances for larger listening areas (with more than one person), it is sometimes better to measure the distance from a given loudspeaker to the closest listener. This is particularly true in multichannel systems.

For a “Party Mode” where there is no single listening position (either due to the size of the crowd, or the fact that the listeners are moving throughout the space), it is usually better to set the Speaker Distances and Speaker Levels to the matching value (e.g. 1.0 m and 0.0 dB).

Multichannel systems with multiple pairs of Beolab 90s

In cases where two or more pairs of Beolab 90s are used in a multichannel system, then care should be taken to ensure that the Preset numbers for the different pairs of loudspeakers match appropriately. This is because the Beovision television sends only one Speaker Preset value to all Power Link and Wireless Power Link outputs.

Background noise during ARC measurements

It is important to ensure that there is as little extraneous noise as possible during the ARC measurement procedure. This includes turning off air conditioning systems or performing the measurements during low-traffic hours, where possible. Short, impact noises such as a single footstep are not problematic. However, continuous sounds such as an idling truck or a humming air conditioning motor will affect the measurement.

ARC filter calculation time

When creating an ARC filter that uses the measurements from more than one ARC Zone, it is advisable to wait until the first calculation is done before including the second Zone.

Troubleshooting

13.1 Some features in the Beolab 90 controls are disabled

When connected to many Bang & Olufsen sources via Power Link or Wireless Power Link, some features in the Beolab 90 may be disabled. This is to avoid errors such as mis-calibration of the volume setting with other loudspeakers in a surround configuration or duplication of processing (e.g. turning up the Bass controller twice: once in the source and once in the loudspeaker).

13.2 Echo problems

13.2.1 Multiroom audio systems

When a Beolab 90 is used with a third-party multiroom system, the loudspeaker's Latency Mode should be set to "Low" in order to reduce the delay time of the Beolab 90 to a minimum. If the Latency Mode is set to "High" and if it is impossible to adjust the expected loudspeaker latency in the multiroom system, then the Beolab 90's latency will be high enough that they appear to produce an audible echo relative to other loudspeakers in the system.

13.2.2 Surround Processors

When a Beolab 90 is used with an older Bang & Olufsen surround processor (such as the BeoSystem 3 or earlier devices) or a third-party surround processor, the loudspeaker's Latency Mode should be set to "Low" in order to reduce the delay time of the Beolab 90 to a minimum. This can be done manually using the control interface (see section 5.10.1), or set as the default for the preset triggered by the audio input connected to the television.

If the Latency Mode is set to "High" and if it is impossible to adjust the

expected loudspeaker latency in the surround processor, then the Beolab 90's latency will be high enough that they appear to produce an audible echo relative to other loudspeakers in the system.

It may be possible to "trick" some surround processors into compensating for Beolab 90's latency in High Latency Mode by adding 34.3 m (112.5 feet) to their actual distance from the listening position. This value corresponds to a 100 ms latency.

When used in Low Latency Mode, 8.6 m (28.1 feet) should be added to the actual distance from the listening position. This value corresponds to an 25 ms latency.

13.3 Loudspeakers don't turn on automatically

If the Beolab 90s are set to recognise the Wireless Power Link / WiSA input, then all cabled inputs are disabled.

It is possible that the Detection Threshold, described in Section 6.2.2 on page 28, is set to too high a value to detect the signal.

13.4 Loudspeakers never shut off

13.4.1 Analogue sources

Adjust the Detection Threshold higher as described in Section 6.2.2 on page 28 to a higher value to prevent it from detecting noise on the input cable.

13.4.2 Digital sources

S/PDIF and Optical

Ensure that the signal on the digital connection either shuts down, or transmits a "digital black" signal. The Beolab 90 detects *any* non-zero signal on these digital inputs and will turn on automatically as a result.

13.5 The application and/or web interface do not work

Ensure that the Digital Power Link cable between the Primary and Secondary loudspeakers is connected.

Ensure that the loudspeakers and the device are connected to the same network.

13.6 Loudspeakers are distorting at low levels

The Maximum Input Level as described in Section 6.2.3 on page 28 may be set to too low a value to be compatible with the audio source. This can cause the input of the Beolab 90 to clip.

13.7 Loudspeakers are noisy / too quiet

If the source has a variable output level, then the best strategy for gain management is to increase the source's output level to maximum and use the volume control of the Beolab 90s. This will ensure the lowest possible noise floor of the overall system.

It is also important to ensure that the Maximum Input Level as described in **Maximum Input Voltage** on page 28 is set to the correct value for the source device. Using too high a setting will result in an elevated noise floor.

See Section 6.2.5 on Input Impedance

13.8 USB Audio not working

The USB Audio input will only accept PCM signals up to 192 kHz.

If your source is outputting DoP (also known as DSD over PCM) or PCM signals at higher sampling rates (e.g. DXD at 384 kHz) there will be no audio output from the loudspeaker.

13.9 S/PDIF input not working

The S/PDIF input will only accept PCM signals up to 192 kHz.

If your source is outputting DoP (also known as DSD over PCM) or PCM signals at sampling rates above 192 kHz (e.g. DXD at 384 kHz) there will be no audio output from the loudspeaker.

13.10 Optical input not working

The Optical input will not accept sampling rates above 96 kHz due to unreliability of an optical digital audio connection at higher sampling rates.

13.11 Automatic switching of inputs not behaving as expected

If you are using the Automatic input selection, there may be cases where the loudspeaker does not behave as you would intuitively expect due to the Time out parameter of the currently selected source. This is best explained by giving examples.

Take the case where you are playing audio from two sources, a CD player connected to the S/PDIF input and a turntable connected to the XLR input (via an RIAA preamplifier), and let us assume that the S/PDIF input has a higher selection priority than the XLR

input. In this case, the loudspeakers will play the CD signal. If you then press STOP on the CD player, the loudspeakers will not switch to the signal on the XLR input (the turntable) until the S/PDIF input's time out duration has passed. (See Section 6.2.4 for a detailed description of the Time-out parameter.)

This behaviour would also be true if you were first playing a signal on the CD player, you press STOP, and then you start playing a signal on the turntable. Again, until the S/PDIF input's time-out duration has passed, the signal on the XLR input (from the turntable) will not be automatically selected by the Beolab 90.

Appendix 1: Recommendations for Critical Listening

14.1 Loudspeaker Configuration

The Beolab 90 provides you with an extremely wide range of parameters that can be used to adjust the timbral and spatial presentation of your recordings for various listening rooms, loudspeaker placements and listening positions. However, it is always best to start with an optimal configuration in your listening room.

First consider the relationship between the loudspeakers and the listening position itself. The two loudspeakers and the listening position should be the three corners of an equilateral triangle. This means that the distance from each loudspeaker to the listening position should be the same as the distance between each loudspeaker. This also means that the loudspeakers will be 30° away from the front, centre location, directly in front of the listening position.

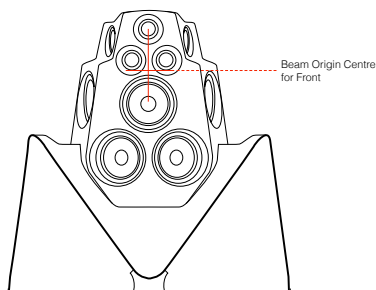

Figure 14.1: The centre of the sound beam in the vertical plane is level with a position between the bottom two tweeters and the top midrange driver as shown (at a height of 108.6 cm from the floor).

Secondly, the two loudspeakers should be “toed-in” by 30° . This means that they should be slightly rotated so that they are both facing the listening position. This is shown in Figure 14.2.

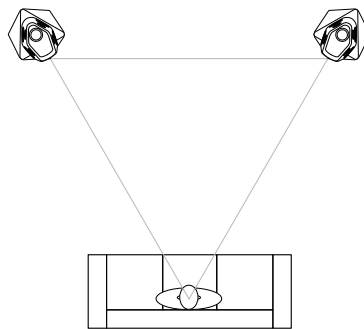

Figure 14.2: A “perfect” loudspeaker configuration with Beolab 90s. Both loudspeakers are aimed at the listening position. The distance from the listening position to each loudspeaker is the same as the distance between the two loudspeakers.

If possible, the height of the listening chair should be set so that the listener’s ears are level with the centre of the vertical beam, shown in Figure 14.1.

The next consideration is symmetry within your listening room. It is commonly recognised that the best stereo imaging will be achieved if the listening configuration (the triangle formed with the listener and the two loudspeakers) is placed in left-right centre of the room. Therefore, the side walls will both be the same distance from the listening position, and the loudspeakers will have the same distance to its adjacent walls. This is to say that the distance from the left loudspeaker to the left wall is the same as the distance between the right loudspeaker and the right wall. The distance to the front wall (behind the loudspeakers) should be the same for both loudspeakers, but certainly does not have to be the same as the distance to the side walls.

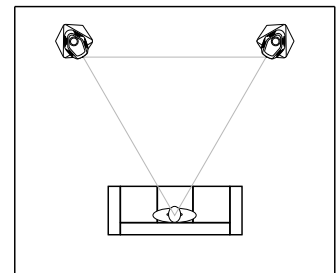

Figure 14.3: An optimal placement for the loudspeakers with respect to adjacent walls. Note that the distance between each loudspeaker and its closest side wall are identical, and that the distances from the loudspeakers to the front wall are also matched.

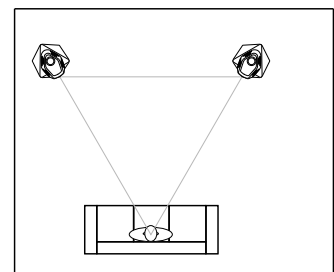

Figure 14.4: An less-optimal placement for the loudspeakers with respect to adjacent walls. Note that the distances from the loudspeakers to the front wall are matched, however, the distance between each loudspeaker and its closest side wall are not identical.

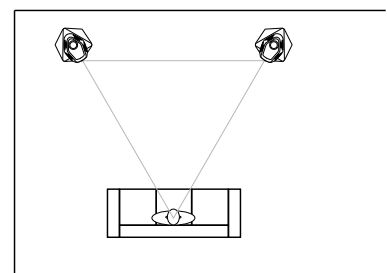

Figure 14.5: Another example of a less-optimal placement for the loudspeakers with respect to adjacent walls. The distances from the loudspeakers to the front wall are matched, however, the right loudspeaker and lacks a side wall nearby.

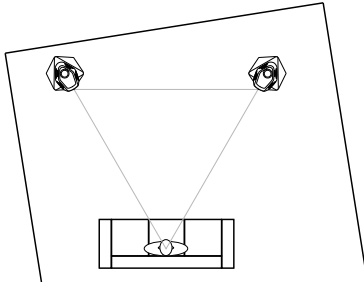

Figure 14.6: An example of a worst-case placement of loudspeakers with respect to the listening room. No two distances between a loudspeaker and an adjacent wall match each other.

It should be noted that the primary casualty of poor loudspeaker placement in a listening room will be the spatial representation of your recordings. The precision and accuracy of the stereo imaging, as well as the sensation of envelopment from the recording will be adversely affected by early reflection patterns that are not matched for the two loudspeakers. This problem is minimised by using Beolab 90's narrow beam width, however, even this mode can benefit from correct loudspeaker placement in the room.

Finally, it is recommendable (but certainly not required) that the loudspeakers be positioned a minimum of 1 m from the closest walls. The Active Room Compensation algorithm will compensate for changes in the Beolab 90's timbral response caused by adjacent boundaries. However, placing the loudspeakers slightly distant from reflective surfaces will reduce these boundary effects, and therefore also reduce the amount of compensation that is required by the ARC filters.

14.2 Listening Room Acoustics

The Beolab 90 has two features that can overcome some detrimental effects of the listening room's acoustical behaviour (**Beam Width Control** and **Active Room**

Compensation). However, the sound of any loudspeaker can be optimised by improving the room's acoustics.

One of the main acoustical problems in listening rooms is that of room modes or resonances. These occur because the room behaves very much like an organ pipe, naturally "singing" at specific frequencies that are determined by the dimensions of the room. Without correct acoustical treatment, these resonances are almost unavoidable. It is preferred to ensure that the resonances in the room's three dimensions (length, width, and height) do not overlap each other. This means that the better listening rooms have complex relationships between these three dimensions. For example, a "worst case" for a listening room would be a cube, where all three dimensions are identical, thus all resonances have the same frequencies. A next-worst case is one where a dimension is a multiple of another, for example, a room that is 9m x 6m x 3m. In a best case, the ratios of the room's dimensions would have non-simple values (e.g. 1 : 2.16 : 2.96 - so, as an example, 3m x 6.48m x 8.88m).¹

A second issue in many listening rooms is that of hard, reflective surfaces - particularly in locations where the sound from the loudspeaker is directly reflected to the listening position. There are two ways to alleviate this problem: absorption and diffusion. In order to absorb a sound wave so that it does not reflect off a surface, an absorptive material such as fibreglass insulation or acoustical foam must be placed on the surface, or in the path taken by the reflection. A reflection can be diffused by making the reflective surface irregular. For example, placing a bookcase at the point of reflection will help as a diffusor if the books are arranged in random heights and depths.

Finally, it is wise to absorb the sound waves that would be reflected off the floor (e.g. with carpet or a rug) and ceiling (using absorptive ceiling tiles).

This will also help to reduce the overall reverberation time of the room.

14.3 Loudspeakers

For "critical" or "serious" listening sessions, it is recommended that the upper fabric frame be removed from the loudspeaker's high speaker section.

14.4 Source Devices

When connecting an audio source to the Beolab 90, there are some basic, general rules that should be followed in order to get the optimal performance from your system. Note that these are general rules - so there are exceptions.

- If possible, the source should be connected to the Beolab 90 using a digital audio connection.
- If the source device has a volume control it should be disabled and the Beolab 90's volume control should be used instead
- If the source has two analogue outputs: one volume-regulated and the other at a fixed level, the fixed-level output should be used
- If you are connecting a source using a line-level analogue input (RCA or XLR), check the source device's datasheet to find its maximum output level and set the value appropriately on the Beolab 90 (See Section 6.2.3). If the maximum output of your device is greater than the Beolab 90's maximum possible setting (6.5 V RMS) then it is recommendable that the source device's output level is reduced if possible, either within its own settings or using an external attenuator. Figure 14.7 shows the necessary attenuation to reduce various voltage levels to 6.5 V RMS.

¹See "Room dimensions for small listening rooms" by Dr. Trevor Cox for a good introduction to this topic.

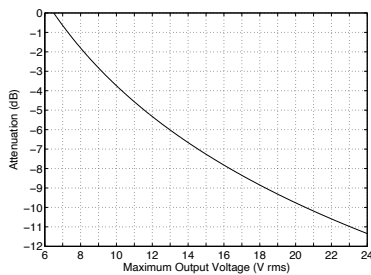

Figure 14.7: The minimum attenuation required to apply to a source with a given Maximum Output level to reduce it to 6.5 V rms in order to prevent clipping the Beolab 90 analogue inputs.

14.5 Cable recommendations

There are innumerable beliefs and opinions, both founded and unfounded, regarding cables used for connecting audio devices. The following is a small set of recommendations that are based on common practices for wiring professional audio systems such as are found in recording and mastering studios. Decisions regarding the specific the brand or construction of the cables used for connecting Beolab 90 are left to the reader's preferences.

14.5.1 Analogue cables

In order to ensure that the noise floor of analogue sources is as low as possible, the following guidelines are recommended:

Use cables with good shielding (or "screening") to reduce RF (Radio Frequency) interference on the audio signals from external sources.

When connecting the XLR input to the XLR output of a source device, use twisted pair (preferably bonded-pair) or "starquad" cables to ensure the best possible matching of low-frequency magnetic interference noise at the differential input. This will ensure the highest possible common mode rejection and lowest noise floor. Note, however, that the use of starquad cable construction generally has a higher inherent capacitance than a

twisted pair cable of the same length and will therefore have a higher loss of high-frequency signals over longer cable runs.

Avoid ground loops when connecting audio devices to each other.²

In order to reduce magnetic inductance of interference (typically 50 Hz or 60 Hz "hum") from power cables on the audio inputs, it is also good practice to physically separate signal cables and mains cables as much as possible. In cases where these cables must cross each other, it is recommended that they cross at a 90° angle.

For a thorough guide to installation of high-end audio equipment, "Audio Systems Design and Installation" by Philip Giddings is highly recommended. Although this is book intended for installation of audio devices in recording and mastering studios, the practices and recommendations detailed therein are also applicable to consumer-level audio equipment.

14.5.2 Optical cables

It is recommended that high-quality optical cables are used for the Beolab 90, particularly for longer cable runs. This is due to the fact that there is attenuation (dimming or loss of light intensity) of the optical signal on the plastic or glass fibre in the cable. This attenuation is proportional (in dB) to the length of the cable. Therefore, in order to ensure that the optical receiver on the Beolab 90 has an adequate signal at its input, the light attenuation on the cable should be minimised either by using short cables and/or high-quality optical fibre.

Traditionally, many people have claimed that optical digital signals are less reliable than electrical connections (such as the AES/EBU and S/PDIF protocols) due to higher levels of jitter caused by the limitations of the rise and fall time of the LED in the transmitter. The Beolab 90 uses a very-high-quality sampling rate

converter at its input for all digital signals which attenuates the jitter of incoming sources, thereby reducing this concern considerably.³

14.5.3 S/PDIF cables

When connecting a source to Beolab 90's S/PDIF input, it is recommended that a cable with a 75 Ω impedance is used. This will ensure that there are no reflections of the signal on the cable which may increase the level of jitter at the input of the Beolab 90. Note that this recommendation is particularly true for longer cable runs. It should, however, be stated that the sampling rate converter at the digital inputs of the Beolab 90 is very effective at attenuating jitter artefacts caused either by the signal source or problems in the cabling.

14.6 AC mains cables

It is highly recommended that an additional device used to filter the AC power from the mains (sometimes called an "audiophile mains filter" or "power purifier", for example) *not* be used with the Beolab 90. This is because the internal power supply of the Beolab 90 has a custom-designed filter that reduces noise on its AC mains input. This filter has been optimised for the time-variant current demands of the Beolab 90, making a generic external filter redundant (at best) or detrimental (at worst) to the performance of the loudspeaker.

Similarly, it is unnecessary to use a so-called "exotic" or "audiophile" mains cable for the Beolab 90.

²Internally, the shield and the audio ground (Pin 1) of the XLR inputs are connected using a "star ground" topology.

³See Robert W. Adams's article, "Clock Jitter, D/A Converters and Sample-Rate Conversion" in The Audio Critic, Issue No. 21 (Spring, 1994) for a primer on this topic.

Appendix 2: Introduction to Parametric Equalisers

Almost all sound systems offer *bass* and *treble* adjustments for the sound – these are basically coarse versions of a more general tool called an *equaliser* that is often used in recording studios.

Once upon a time, if you made a long-distance phone call, there was an actual physical connection made between the wire running out of your telephone and the telephone at the other end of the line. This caused a big problem in signal quality because a lot of high-frequency components of the signal would get attenuated along the way due to losses in the wiring. Consequently, booster circuits were made to help make the relative levels of the various frequencies more *equal*. As a result, these circuits became known as *equalisers*. Nowadays, of course, we don't need to use equalisers to fix the quality of long-distance phone calls (mostly because the communication paths use digital encoding instead of analogue transmission), but we do use them to customise the relative balance of various frequencies in an audio signal. This happens most often in a recording studio, but equalisers can be a great personalisation tool in a playback system in the home.

The two main reasons for using equalisation in a playback system such as the Beolab 90s are *personal preference* and *compensation for the acoustical behaviour of the listening room*.

Equalisers are typically comprised of a collection of filters, each of which has up to 4 “handles” or “parameters” that can be manipulated by the user. These parameters are

- Filter Type
- Gain
- Centre Frequency
- Q

15.1 Filter Type

The *Filter Type* will let you decide the relative levels of signals at frequencies within the band that you're affecting.

Although there are up to 7 different types of filters that can be found in professional parametric equalisers, the Beolab 90 contains the three most-used of these:

- Low-shelving Filter
- High-shelving Filter
- Peaking Filter

15.1.1 Low-shelving Filter

In theory, a *low-shelving filter* affects gain of all frequencies below the centre frequency by the same amount. In reality, there is a band around the centre frequency where the filter transitions between a gain of 0 dB (no change in the signal) and the gain of the affected frequency band.

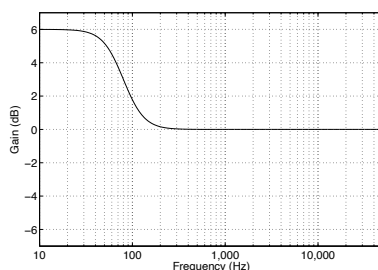

Figure 15.1: Example of a low-shelving filter with a positive gain. Frequencies below approximately 80 Hz have been affected.

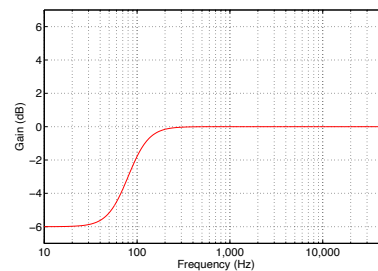

Figure 15.2: Example of a low-shelving filter with a negative gain. Frequencies below approximately 80 Hz have been affected.

The centre frequency of a low-shelving filter used in the Beolab 90 is the frequency where the gain is one half the maximum (or minimum) gain of the filter. For example, in Figure 15.1, the gain of the filter is 6 dB. The centre frequency is the frequency where the gain is one-half this value or 3 dB, which can be found at 80 Hz.

Some care should be taken when using low-shelving filters since their affected frequency bands extend to 0 Hz or DC. This can cause a system to be pushed beyond its limits in extremely low frequency bands that are of little-to-no consequence to the audio signal. Note, however, that this is less of a concern for the Beolab 90, since it is protected against such abuse.

15.1.2 High-shelving Filter

In theory, a *high-shelving filter* affects gain of all frequencies above the centre frequency by the same amount. In reality, there is a band around the centre frequency where the filter transitions between a gain of 0 dB (no change in the signal) and the gain of the affected frequency band.

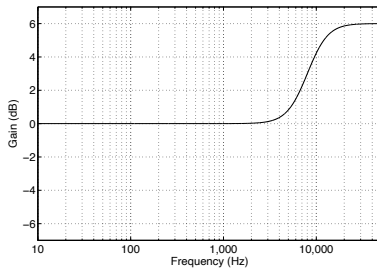

Figure 15.3: Example of a high-shelving filter with a positive gain. Frequencies above approximately 8 kHz have been affected.

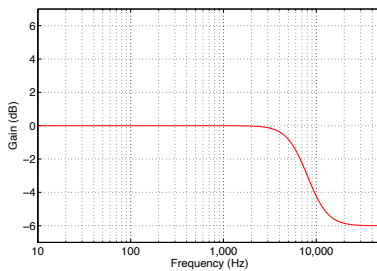

Figure 15.4: Example of a high-shelving filter with a negative gain. Frequencies above approximately 8 kHz have been affected.

The centre frequency of a high-shelving filter used in the Beolab 90 is the frequency where the gain is one half the maximum (or minimum) gain of the filter. For example, in Figure 15.4, the gain of the filter is -6 dB. The centre frequency is the frequency where the gain is one-half this value or -3 dB, which can be found at 8 kHz.

Some care should be taken when using high-shelving filters since their affected frequency bands can extend beyond the audible frequency range. This can cause a system to be pushed beyond its limits in extremely high frequency bands that are of little-to-no consequence to the audio signal.

15.1.3 Peaking Filter

A *peaking filter* is used for a more local adjustment of a frequency band. In this case, the centre frequency of the filter is affected most (it will have the gain of

the filter applied to it) and adjacent frequencies on either side are affected less and less as you move further away. For example, Figure 15.5 shows the response of two peaking filters, both with a centre frequency of 1 kHz and gains of 6 dB (the black curve) and -6 dB (the red curve). As can be seen there, the maximum effect happens at 1 kHz and frequency bands to either side are affected less so.

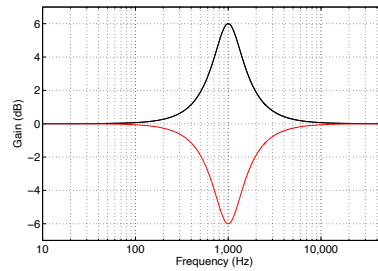

Figure 15.5: Example of two peaking filters. The black curve shows a filter with a positive gain, the red curve shows the reciprocal with a negative gain. The centre frequency of both filters is 1 kHz.

You may notice in Figure 15.5 that the black and red curves are symmetrical; in other words, they are identical except in polarity of the gain. This is a particular type of peaking filter called a *reciprocal peak/dip filter* – so-called because these two filters, placed in series, can be used to cancel each other's effects on the signal. Beolab 90 uses reciprocal peak/dip filters.

15.2 Gain

If you need to make *all* frequencies in your audio signal louder, then you just need to increase the volume. However, if you want to be a little more selective and make some frequency bands louder (or quieter) and leave other bands unchanged, then you'll need an equaliser. So, one of the important questions to ask is "how much louder?" or "how much quieter?" The answer to this question is the *gain* of the filter – this is the amount by which is signal is increased or decreased in level.

The gain of an equaliser filter is almost always given in *decibels* or *dB*¹. This is a scale based on logarithmic changes in level. Luckily, it's not necessary to understand logarithms in order to have an intuitive feel for decibels. There are really just three things to remember:

- A gain of 0 dB is the same as saying "no change".
- Positive decibel values are louder, negative decibel values are quieter.
- Adding approximately 6 dB to the gain is the same as saying "two times the level". (Therefore, subtracting 6 dB is half the level.)

15.3 Centre Frequency

The next question to answer is "which frequency bands do you want to affect?" This is partially defined by the *centre frequency* or *F_c* of the filter. This is a value that is measured in the number of cycles per second², labelled *Hertz* or *Hz*.

Generally, if you want to increase (or reduce) the level of the bass, then you should set the centre frequency to a low value (roughly speaking, below 125 Hz). If you want to change the level of the high frequencies, then you should set the centre frequency to a high value (say, above 8 kHz).

15.4 Q

In all of the above filter types, there are transition bands – frequency areas where the filter's gain is changing from 0 dB to the desired gain. Changing the filter's *Q*³ allows you to alter the shape of this transition. The lower the *Q*, the smoother the transition. In both the case of the shelving filters and the peaking filter, this means that a wider band of frequencies will be affected. This can be seen in the examples in Figures 15.6 and 15.7.

¹The "B" is a capital because it's named after Alexander Graham Bell.

²This is the number of times a loudspeaker driver will move in and out of the loudspeaker cabinet each second.

³Note that, although the term "Q" is used throughout this manual and the Beolab 90 interface for both peaking and shelving filters, this is incorrect. To be technically correct, the term "S" (or shelf slope) should be used for shelving filters.

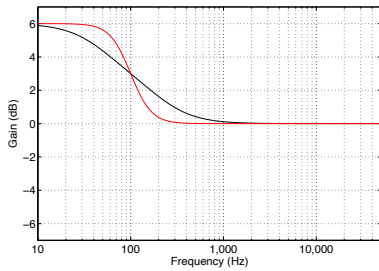

Figure 15.6: Example of two low-shelving filters. The black curve shows a filter with a Q of 0.4, the red curve shows the a filter with a Q of 1. For both filters, the centre frequency is 100 Hz and the gain is +6 dB.

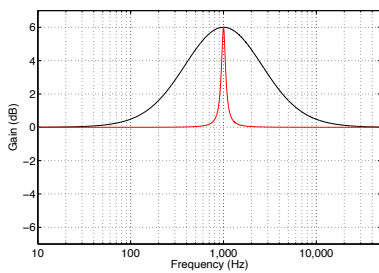

Figure 15.7: Example of two peaking filters. The black curve shows a filter with a Q of 0.5, the red curve shows the a filter with a Q of 8. For both filters, the centre frequency is 1 kHz and the gain is +6 dB.

It should be explained that the Q parameter can cause a shelving filter to behave slightly strangely. When the Q of a shelving filter exceeds a value of 0.707, the gain of the filter will “overshoot” its limits. For example, as can be seen in Figure 15.8, a filter with a gain of 6 dB and a Q of 4 will actually have a gain of almost 13 dB and will attenuate by almost 7 dB.

This over- and undershooting of the filter’s magnitude response is one reason that the Q of the high-shelving and low-shelving filters in the Beolab 90’s parametric equaliser have been limited to a maximum value of 1.

Note that, when the Q is set to a value of 1, then the resulting overshoot of the filter, in decibels, is approximately 7.4% higher than the stated gain of the filter. For example, if Gain = 6 dB and Q = 1, then the maximum actual gain of the filter will be $6 * 1.074 = 6.44$ dB. If Gain = 3 dB and Q = 1, then the

maximum actual gain of the filter will be $3 * 1.074 = 3.22$ dB.

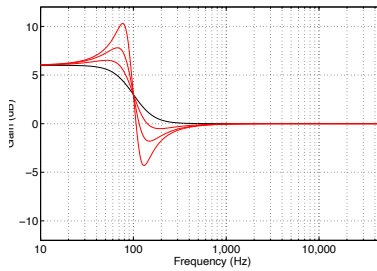

Figure 15.8: Example of low-shelving filters with a Q of more than 1. The black curve shows a filter with a Q of 0.7 for reference, the red curves shows filters with Q’s of 1, 2, and 4. The centre frequency of this filter is 100 Hz and the gain is +6 dB. *Note that some of these values are not possible in the parametric equaliser in Beolab 90.*

Appendix 3: The Influence of Listening Room Acoustics on Loudspeakers

A room comprised of large flat reflective surfaces with little acoustical absorption has a very different acoustical behaviour from a recording or mastering studio where the final decisions about various aspects of a recording are made. Consequently, this must have an effect on a listener's perception of a recording played through a pair (assuming stereo reproduction) of loudspeakers in that room. The initial question to be asked is "what, exactly, are the expected effects of the room's acoustical behaviour in such a case?" The second is "if the room has too much of an effect, how can I improve the situation (e.g. by adding absorption or changing the physical configuration of the system in the room)?" The third, and possibly final question is "how can a loudspeaker compensate (or at least account) for these effects?"

The effect a room's acoustical behaviour has on a loudspeaker's sound can, at a simple level, be considered under three general headings:

- **Early Reflections**
- **Room Modes**
- **Reverberation**

16.1 Early Reflections

Early reflections, from sidewalls and the floor and ceiling, have an influence on both the timbre (tone colour) and the spatial characteristics of a stereo reproduction system. We will only discuss the timbral effects in this section.

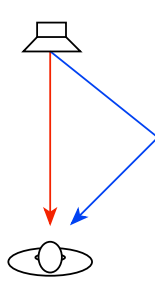

Figure 16.1: The sound arriving at a listener from a loudspeaker in a room with only one wall. Note that the sound arrives from two directions - the first is directly from the loudspeaker (in red). The second is a "first reflection" off the wall (in blue).

Let's start by assuming that you have a loudspeaker that has a magnitude response that is perfectly flat - at least from 20 Hz to 20 kHz. We will also assume that it has that response regardless of which direction you measure it in - in other words, it's a perfectly omnidirectional loudspeaker. The question is, "what effect does the wall reflection have on the measured response of the loudspeaker?"

Very generally speaking, the answer is that you will get a higher level at some frequencies (because the direct sound and the reflection add constructively and reinforce each other) and you will get a lower level at other frequencies (because the direct sound and the reflection work against each other and "cancel each other out"). What is potentially interesting is that the frequencies that add and the frequencies that cancel alternate as you go up the frequency range. So the total result looks like a comb (as in a comb that you use to comb your hair, if, unlike me, you have hair to comb). For example, take a look at Figure 16.2.

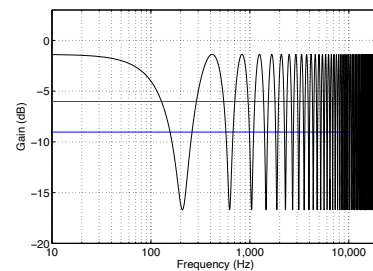

Figure 16.2: Distance to loudspeaker = 2 m. Distance to wall = 1 m. Wall is perfectly reflective and the loudspeaker is perfectly omnidirectional. The red line is the magnitude response of the direct sound. The blue line is the magnitude response of the reflected sound. The black line is the magnitude response of the combination.

You can see that, at the very low end, the reflection boosts the level of the loudspeaker by a approximately 5 dB (or almost two times the level) at the listening position. However, as you go up in frequency, the total level drops to about 15 dB less before it starts rising again. As you go up in frequency, the level goes up and down. This alternation actually happens at a regular frequency spacing (e.g. a notch at multiples of 200 Hz) but it doesn't look regular because the X-axis of the plot is logarithmic (which better represents how we hear differences in frequency).

What happens if we move the wall further away? Well, two things will happen. The first is that the reflection will be quieter, so the peaks and notches won't be as pronounced. The second is that the spacing of the peaks and notches in frequency will get closer together. In other words, the effect starts at a lower frequency as can be seen in the example in Figure 16.3.

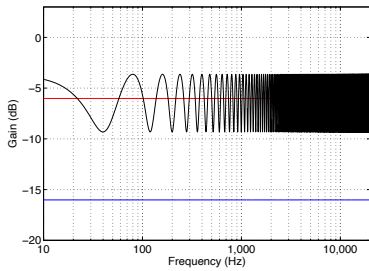

Figure 16.3: Distance to loudspeaker = 2 m. Distance to wall = 3 m. Wall is perfectly reflective and the loudspeaker is perfectly omnidirectional. The red line is the magnitude response of the direct sound. The blue line is the magnitude response of the reflected sound. The black line is the magnitude response of the combination.

Conversely, if we move the wall closer, we do the opposite (the problem gets worse, but starting at a higher frequency), as can be seen in Figure 16.4.

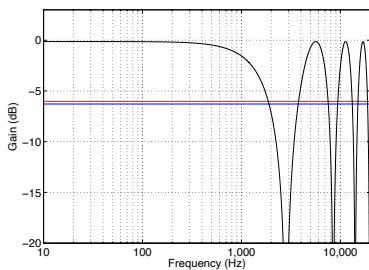

Figure 16.4: Distance to loudspeaker = 2 m. Distance to wall = 0.25 m. Wall is perfectly reflective and the loudspeaker is perfectly omnidirectional. The red line is the magnitude response of the direct sound. The blue line is the magnitude response of the reflected sound. The black line is the magnitude response of the combination.

So, if you have a room with only one wall which is perfectly reflective, and you have a perfectly omnidirectional loudspeaker, then you can see that your best option is to either put the loudspeaker (and yourself) very far or very close to the wall. That way the artefacts caused by the reflection are either too quiet to do any damage, or have an effect that starts at too high a frequency for you to care. Then again, most rooms have more than one wall, the walls are not perfectly reflective, and the loudspeaker is not perfectly omnidirectional.

So, what happens in the case where the loudspeaker is more directional or you have some absorption (better known as “fuzzy stuff”) on your walls? Well, either of these cases will have basically the same effect in most cases since loudspeakers are typically more directional at high frequencies – so you get less high end directed towards the wall. Alternatively, fuzzy stuff tends to soak up high frequencies. So, in either of these two cases, you’ll get less high end in the reflection. Let’s simulate this by putting a low pass filter on the reflection, as shown in Figure 16.5, 16.6 and 16.7 which have identical distances as the simulations in Figures 16.2, 16.3, and 16.4 – for comparison.

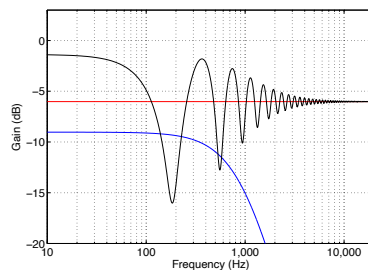

Figure 16.5: Distance to loudspeaker = 2 m. Distance to wall = 1 m. Wall is absorptive and/or the loudspeaker is directional at high frequencies. The red line is the magnitude response of the direct sound. The blue line is the magnitude response of the reflected sound. The black line is the magnitude response of the combination.

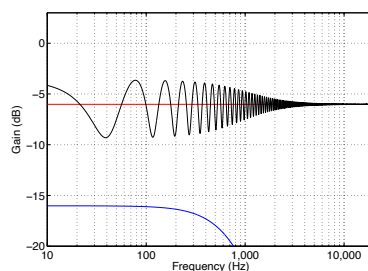

Figure 16.6: Distance to loudspeaker = 2 m. Distance to wall = 3 m. Wall is absorptive and/or the loudspeakers is directional at high frequencies. The red line is the magnitude response of the direct sound. The blue line is the magnitude response of the reflected sound. The black line is the magnitude response of the combination.

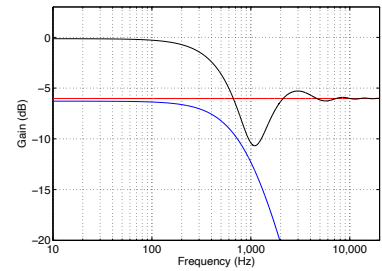

Figure 16.7: Distance to loudspeaker = 2 m. Distance to wall = 0.25 m. Wall is absorptive and/or the loudspeaker is directional at high frequencies. The red line is the magnitude response of the direct sound. The blue line is the magnitude response of the reflected sound. The black line is the magnitude response of the combination.

What you can see in all three of the previous plots is that, as the high frequency content of the reflection disappears, there is less and less effect on the total. The bottom plot is basically a proof of the age-old rule of thumb that says that, if you put a loudspeaker next to a wall, you’ll get more bass than if it’s farther from the wall. Since there is not much high frequency energy radiated from the rear of most loudspeakers, Figure 16.7 is a pretty good general representation of what happens when a loudspeaker is placed close to a wall. Of course, the exact behaviour of the directivity of the loudspeaker will be different – but the general shape of the total curve will be pretty similar to what you see there.

So, the end conclusion of all of this is that, in order to reduce undesirable artefacts caused by a wall reflection, you can do any combination of the following:

- move the loudspeaker very close to the wall
- move the loudspeaker farther from the wall
- sit very close to the wall
- sit farther away from the wall
- put absorption on the wall

However, there is one interesting effect that sits on top of all of this – that is the fact that what you’ll see in a

measurement with a microphone is not necessarily representative of what you'll hear. This is because a microphone does not have two ears. Also, the direction the reflection comes from will change how you perceive it. A sidewall reflection sounds different from a floor reflection. This is because you have two ears - one on each side of your head. Your brain uses the sidewall reflections (or, more correctly, how they relate to the direct sound) to determine, in part, how far away a sound source is. Also, since, in the case of sidewall reflections, your two ears get two different delay times on the reflection (usually), you get two different comb-filter patterns, where the peaks in one ear can be used to fill in the notches in the other ear and vice versa. When the reflection comes from the floor or ceiling, your two ears get the same artefacts (since your two ears are the same distance to the floor, probably). Consequently, it's easily noticeable (and it's been proven using science!) that a floor or ceiling reflection has a bigger timbral effect on a loudspeaker than a lateral (or sideways) reflection.

16.2 Room Modes

Room modes are a completely different beast - although they exist because of reflections. If you pluck a guitar string, you make a deflection in the string that moves outwards until it hits the ends of the string. It then bounces back down the string, bounces again, etc. etc. As the wave bounces back and forth, it settles in to a total result where it looks like the string is just bouncing up and down like a skipping rope. The longer the string, the lower the note, because it takes longer for the wave to bounce back and forth on the string. You can also lower the note by lowering the tension of the string, since this will slow down the speed of the wave moving back and forth on it. The last way to lower the note is to make the string heavier (e.g. by making it thicker) - since a heavier string is harder to

move, the wave moves slower on it.

The air in a pipe behaves exactly the same way. If you "pluck" the air in the middle of a pipe (say, by clapping our hands, or coughing, or making any noise at all) then the sound wave travels along the pipe until it hits the end. Whether the end of the pipe is capped or not, the wave will bounce back and travel back through the pipe in the opposite direction from whence it came.¹ As the wave bounces back and forth off the two ends of the pipe, it also settles down (just like the guitar string) into something called a "standing wave". This is the pipe's equivalent of the skipping rope behaviour in the string. The result is that the pipe will "resonate" or ring at a note. The longer the pipe, the lower the note because the speed of the sound wave moving in air in the pipe stays the same, but the longer the pipe, the longer it takes for the wave to bounce back and forth. This is basically how all woodwind instruments work.

What's interesting is that, in terms of resonance, a room is basically a big pipe. If you "pluck" the air in the room (say, by making sound with a loudspeaker) the sound wave will move down the room, bounce off the wall, go back through the room, bounce off the opposite wall, etc. etc. (Of course, other things are happening, but we'll ignore those.) This effect is most obvious on a graph by putting some sound in a room and stopping suddenly. Instead of actually stopping, you can see the room "ringing" (exactly in the same way that a bell rings when it's been hit) at a frequency that gradually decays as time goes by. However, it's important to remember that this ringing is always happening - even while the sound is playing. So, for example, a kick drum "thump" comes out of the speaker which "plucks" the room mode and it rings, while the music continues on.

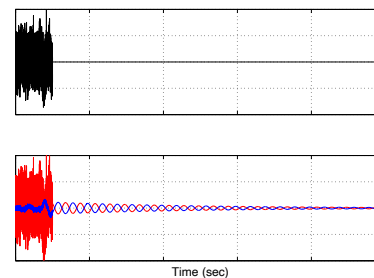

Figure 16.8: The concept of the effect of a room mode and Active Room Compensation. See the associated text for an explanation.

Figure 16.8 shows the concept of the effect of a room mode and how it's dealt with by Active Room Compensation. The sound coming out of the loudspeaker is shown on the top plot, in black. The response of the loudspeaker and a single room mode is shown below, in red. You can see there that the room mode keeps "ringing" at one frequency after the sound from the loudspeaker stops.

There are two audible effects of this. The first is that, if your music contains the frequency that the room wants to resonate at, then that note will sound louder. When you hear people talk of "uneven bass" or a "one-note-bass" effect, one of the first suspects to blame is a prominent room mode.

The second is that, since the mode is ringing along with the music, the overall effect will be muddiness. This is particularly true when one bass note causes the room mode to start ringing, and this continues when the next bass note is playing. For example, if your room rings on a C#, and the bass plays a C# followed by a D - then the room will continue to at C#, conflicting with the D and resulting in "mud". This is also true if the kick drum triggers the room mode, so you have a kick drum "plucking" the room ringing on a C# all through the track. If the tune is in the key of F, then this will not be pretty.²

In order for the loudspeaker to compensate for the effect of the room mode, it has to not only produce the

¹Whether the pipe is closed (capped) or open only determines the characteristic of the reflection - there will be a reflection either way.

²Do a search for "tritone" or "diabolus in musica".

signal it should (shown in black) but it must also produce a signal that counter-acts the ringing in the room mode. This is shown in the lower plot in blue. As can be seen there (most easily in the ringing after the signal has stopped), the loudspeaker's compensation signal (the blue curve) is the mirror image of the room's "misbehaviour" (in red). If you add these two curves together, the result is that they cancel each other out, and the result is the black curve.

If you would like to calculate a prediction of where you'll have a problem with a room mode, you can use the following equation:

- metric version:
frequency = $172 / (\text{length in m})$
- imperial version:
frequency = $558 / (\text{length in feet})$

This calculation will produce the fundamental frequency of the room mode in Hz for the dimension of the room represented by "length". Your most audible modal problems will be at the frequencies calculated using either of the equations above, and multiples of them (e.g. 2 times the result, 3 times the result, and so on).

So, for example, if your room is 5 m wide, your worst-case modes (for the room's width) will be at $172 / 5 = 34.4$ Hz, as well as 68.8 Hz, 103.2 Hz and so on. Remember that these are just predictions - but they'll come pretty close. You should also remember that this assumes that you have completely immovable walls and no absorption - if this is not true, then the severity of the actual problem will vary accordingly.

Sadly, there is not much you can do about room modes. There are ways to manage them, including, but not exclusive to the following strategies:

- make sure that the three dimensions of your listening room are not related to each other with simple ratios
- put up membrane absorbers or slot absorbers that are tuned to

the modal frequencies

- place your loudspeaker in a node - a location in a room where it does not couple to a problematic mode (however, note that one mode's node is another mode's antinode)
- sit in a node - a location in a room where you do not couple to a problematic mode (see warning above)
- use room correction DSP software such as ARC in the Beolab 90

16.3 Reverberation

Reverberation is what you hear when you clap your hands in a big cathedral. It's the collection of a lot of reflections bouncing from everywhere as you go through time. When you first clap your hands, you get a couple of reflections that come in separated enough in time that they get their own label - "early reflections". After that, there are so many reflections coming from so many directions, and so densely packed together in time, that we can't separate them, so we just call them "reverberation" or "reverb" (although you'll often hear people call it "echo" which is the wrong word to use for this).

Reverb is what you get when you have a lot of reflective surfaces in your room - but since it's so irregular in time and space, it just makes a wash of sound rather than a weird comb-filter effect like we saw with a single reflection. So, although it makes things "cloudy" - it's more like having a fog on your glasses instead of a scratch, or a soft-focus effect on a kitschy photograph of a field of flowers.

16.4 Solutions

As we've seen, if your listening room is normal, you have at least these three basic acoustic problems to deal with. Each problem has a different solution...

The first solution has already been started for you. The final tuning of

every Bang & Olufsen loudspeaker (including the Beolab 90) is voiced in at least four rooms with very different acoustical behaviours ranging from a very "dead" living room with lots of absorptive and diffusive surfaces to a larger and very "live" space with a minimalistic decorating, and large flat surfaces. Once we have a single sound design that is based on the common elements those rooms, we test the loudspeakers in more rooms to ensure that they'll behave well under all conditions.

The second solution is Beolab 90's Active Room Compensation which will correct the effects of boundaries (walls) and room modes on the timbre of the loudspeaker at the listening position(s). Using measurements of the characteristics of the loudspeaker at the listening positions, the ARC algorithm then creates a filter that is used to "undo" these effects. For example, if the loudspeaker is close to a wall (which will generally result in a boosted bass) then the filter will reduce the bass symmetrically. Similarly, ringing caused by room modes will be actively cancelled by both Beolab 90s. That way, the loss in the filter and the gain due to the room will cancel each other.

The third solution is unique to the Beolab 90: Beam Width Control. This allows you to customise the relative levels of the direct sound and the reflected sound at the listening position. The result of this is that, even if you have acoustically reflective side walls, the Beolab 90 can still deliver an accurate and precise representation of the spatial presentation of your stereo recordings.

16.5 Conclusions

Of course, this section does not cover everything there is to know about room acoustics. And, of course, you can't expect a loudspeaker to sound exactly the same in every room. If that were true, there would be no such thing as a "good" concert hall. A room's

acoustical behaviour affects the sound of all sound sources in the room. On the other hand, humans also have an amazing ability to adapt: in other words you “get used to” the characteristics of your listening room.

However, there is no debate that, due to many issues (the first two that come to mind are frequency range and directivity) two different loudspeakers will behave differently from each other in two different rooms. In other words, if you listen to loudspeaker “A” and loudspeaker “B” in a showroom of a shop, you might prefer loudspeaker “A” – but if you took them home, you might prefer loudspeaker “B”. This would not be surprising, since what you hear is not only the loudspeaker but the loudspeaker “filtered” by the listening room. This is exactly why, even with automated room compensation algorithms, some fine tuning may be necessary to achieve a sound that best suits your room and your tastes.

Appendix 4: Loudspeaker Directivity and Distance Perception in Stereo Imaging

17.1 Distance Perception in Real Life

Go to the middle of a snow-covered frozen lake with a loudspeaker and a friend. Sit there and close your eyes and get your friend to place the loudspeaker some distance from you. Keep your eyes closed, play some sounds out of the loudspeaker and try to estimate how far away it is. You will be wrong (unless you're VERY lucky). Why? It's because, in real life with real sources in real spaces, distance information (the information that tells you how far away a sound source is) comes mainly from the relationship between the direct sound and the early reflections from walls in your listening room. If you don't have any early reflections, then you don't have any distance information. Add the early reflections and you can very easily tell how far away it is.¹

17.2 Distance Perception in a Stereo Recording

Recording engineers have a basic trick for controlling the apparent distance to a sound source in a stereo recording using the so-called "dry-to-wet" ratio; in other words, the relative levels of the direct sound and the reverberation. To be honest, this is a bit of an over-simplification, but it's at the level of knowledge one would typically have if one were just starting out recording a budding rock band in a garage.

Many classical recordings are made with a pair of microphones. An instrument that is on the left side of the pair will produce a sound that is slightly louder and/or slightly earlier in the left microphone than in the right microphone. This means that, when you sit in the sweet spot and listen to the stereo recording, you will hear that source on the left side of the stereo image. This effect is true not only for

the direct sound of the instruments arriving at the microphone pair, but also for the acoustic reflections off the various surfaces in the recording space. So, if the recording engineer has been paying attention, the distance information (the relationship between the direct sound and the reflections) has been captured in the recording. This means that when you listen to the recording, you not only can tell where the instruments are from left to right, but also their relative distances.

17.3 Combining the Two

So, we know that early reflections tell your brain how far away the sound source is. Now think to a loudspeaker in a listening room:

Case 1: If you have a listening room that has no sidewalls, then there are no early reflections, and, regardless of how far away the loudspeakers are, a sound source in the recording without early reflections (e.g. a close-mic'ed vocal) will sound closer to you than the loudspeakers.

Case 2: If you have a listening room with early reflections, and the loudspeakers are less directional (such as Beolab 90s with their Beam Width set to Wide or Omni) then the early reflections from the side walls tell you how far away the loudspeakers are. Therefore, the close-mic'ed vocal track from Case 1 cannot sound any closer than the loudspeakers: your brain is too smart to be told otherwise.

Case 3: If you have a listening room with sidewalls and therefore early reflections, but the loudspeakers are directional such that there is no energy being delivered to the side walls, then the result is the same as in Case 1. This time, the level of the early reflections has been reduced because of loudspeaker directivity instead of

wall absorption, but the effect at the listening position is the same. This is the case with Beolab 90 when its Beam Width is set to Narrow.

The conclusion is that, in order to get an accurate and precise representation of the spatial properties in a stereo recording, you should try to minimise the levels of the early reflections from the sidewalls in your listening room. However, this means that you are optimising the sound for the sweet spot, on-axis to both loudspeakers. When listening with friends, it may be necessary to widen the loudspeakers' Beam Widths.

¹This has been proven in various listening tests. For example, go check out "Psychoacoustic Evaluation of Synthetic Impulse Responses" by Per Rubak & Lars G. Johansen as a starting point.

Appendix 5: Microphone placement strategy when creating ARC Zones

As is discussed in [Active Room Compensation](#) on page 21, it is possible to create settings for different *ARC Zones* (or listening areas). This is done by placing a microphone in three different locations within the zone and performing an ARC measurement at each position. This section gives some recommendations regarding where to place the microphone for the measurements.

18.1 General information

18.1.1 Background noise

It is important to ensure that extraneous background noise is kept to a minimum during the measurement procedure. This does not only include mid-range frequencies (e.g. speech) but also low-frequency noise. Therefore, for example, it is recommended that air conditioning systems be turned off, and the measurements are performed during low-traffic hours. This is because, in some cases, the measurement may interpret background noise as artefacts of the room's acoustical behaviour. (For example, the process may result in reduced bass in the loudspeakers if a truck was idling outside the room during the measurement procedure.)

18.1.2 Microphone Orientation and Holder

The microphone should be securely held (e.g. on a camera tripod or microphone stand), pointing upwards as is shown in [Figure 18.1](#).

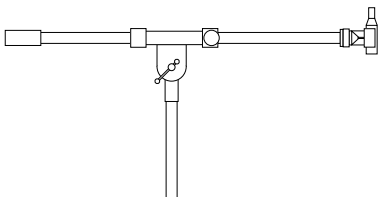

Figure 18.1: Recommended microphone orientation.

It is not recommended that the microphone be hand-held due to the length of the measurement procedure and the fact that the microphone should not move during the measurement. Extraneous noise caused by holding the microphone may also affect the measurement accuracy.

18.1.3 Height

If the ARC measurement is for only one listener who never changes position (e.g. never "slouches" in the listening chair), then the height of the microphone should be roughly the same as the height of that person's ears, typically 100 - 120 cm above the floor.

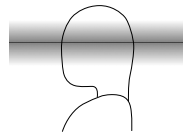

Figure 18.2: Recommended microphone placement height for one listener shown in gray.

If the ARC measurement zone is intended for more than one listening position, or for listeners of different heights, then it may be beneficial to change the vertical position of the microphone for the three measurements. For example, set the centre microphone position at ear-height, the front-left position slightly lower (10-20 cm), and the back-right position slightly higher (10-20 cm). This will provide the calculation with additional information regarding the effects of room modes in the vertical dimension that may benefit listeners of different heights.

18.1.4 Doors and Windows

Doors and windows in the listening room should have the same position during the measurement as when the room will be used for listening. So, if

you normally listen to music with the doors closed, then they should also be closed during the measurement procedure. This is because opening a door or a window can have a significant effect on the acoustical behaviour of a listening room.

If doors may be opened or closed for different listening situations (e.g. patio doors leading from the living room to the outdoors) then two different *ARC Zones* should be created separately for the two different scenarios.

18.2 One listening position

If an *ARC Zone* consists of only one listening position, it is recommended that the three microphone positions are:

- the location of the listener's head, as shown in [Figure 18.3](#)
- on each side of the listening position (approximately 30 cm to either side of the listening position). One placement should be slightly forward (approximately 20 cm) and the other should be slightly behind (approximately 20 cm).

As mentioned above, the microphone should be placed roughly at ear-height.

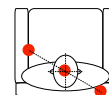

Figure 18.3: Recommended *ARC* microphone placements (in red) for a single listening position.

18.3 More than one listening position

If an ARC Zone consists of more than one listening position (e.g. a sofa) then the measurement should be performed once for each position. Figures 18.4 and 18.5 show a examples of zones consisting of many possible listening positions. The microphone should be placed at three positions (at ear-height) distributed roughly evenly throughout each zone to create the ARC filter for each situation.

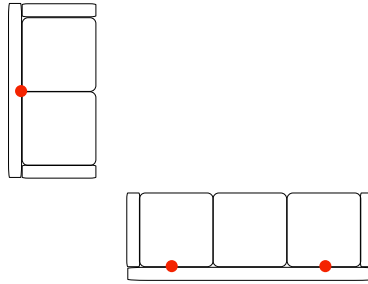

Figure 18.4: Recommended ARC microphone placements (in red) for a multiple listening positions.

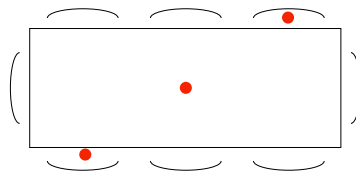

Figure 18.5: Example ARC microphone placements (in red) for a passive listening and background music situations at a dining table.

Note that, in cases where there is overlap between different ARC Zones, the measurements can be combined by combining ARC Profiles in the Beolab 90 interface instead of duplicating measurements. An example of this is shown in Figure 18.6.

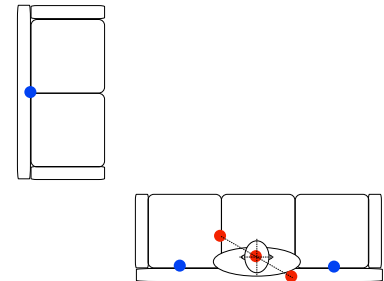

Figure 18.6: An example of avoiding duplicate microphone placements when ARC Zones overlap. The “sweet spot” zone is measured using the microphone placements shown in red. The other listening positions on the sofas are measured for a second ARC Zone using the microphone placements shown in blue. These two are combined by selecting both in the interface to completely cover the entire area.

Appendix 6: ABL - Adaptive Bass Linearisation

19.1 A General Introduction to ABL

Almost all loudspeakers made by Bang & Olufsen include Adaptive Bass Linearisation or ABL. This includes not only our “stand alone” loudspeakers (the Beolab series) but also our smaller “Beosound” loudspeakers and televisions. The only exceptions in the current portfolio are our passive loudspeakers and some headphone/earphone models.

There is no one technical definition for ABL, since it is in continual evolution – in fact it may change from product to product as we learn more and as different products require different algorithms. Speaking very broadly, however, we could say that it reduces the low frequency content sent to a loudspeaker driver (e.g. the woofer) when the loudspeaker is asked to play loudly, but even this is partially inaccurate.

It is important to note that it is *not* the case that this replaces a “loudness function” which may (or may not) be equalising for Equal Loudness Contours (sometimes called “Fletcher-Munson Curves”). However, since (generally) the bass is pulled back when things get loud, it is easy to assume this to be true.

When we are doing the sound design for a loudspeaker (which is based both on measurements and listening), we ensure that we are operating at a listening level that is well within the “linear” behaviour of the loudspeaker and its components. (Typically, the sound design is done at a standard playback level where a -20 dB FS full-band pink noise produces 70 dB SPL (C) at the listening position.)

This means that

- the drivers (usually the woofers) aren't being asked to move too far (in and out)
- the amplifier is operating within

its limits

- the power supply is operating within its limits, and
- nothing (neither the power supply, nor the amplifiers, nor the voice coils) is getting so hot that the loudspeaker's behaviour is altered.

This is what is meant by “linear” – it's fancy word for “predictable”. In addition, it should be stated that if we were listening to loudspeakers at high levels daily, we would get increasingly bad at our jobs due to hearing loss.

So, we do the tuning at a listening level where we know things are behaving: remember that we always do it at the same calibrated level every time for every loudspeaker so that we don't change sound design balance due to shifts associated with equal loudness contours. (If you voice a loudspeaker when it's playing loudly, you'll wind up with a loudspeaker with less bass than if you voiced it quietly. This is because you're automatically compensating for differences in your own hearing at different listening levels.)

After that tuning is done, then we go back to the measurements to see where things will misbehave. For example, in order to compensate for the relatively small cabinet behind the woofer(s) in smaller loudspeakers, we increase the amount of bass that we send to the amplifiers for the woofers as part of the sound design. If we left that bass boost in the tuning when you turn up the volume, the loudspeaker would go up in smoke – or at least sound very bad. This could be because:

- the woofer is being pushed or pulled beyond its limits, or
- because the amplifier clips or
- the power supply cannot supply more current or
- something else.

After the tuning process is complete, we put the loudspeaker in a small torture chamber roughly the size of a clothes closet, put on some dance music (or modified synthetic test signals) and turn up the volume. While that's playing, we're continually monitoring the signal that we're sending to the loudspeaker, the driver excursion, the demands on the electronics (e.g. the amp's, DAC's, power supply, etc.) and the temperature of various components in the loudspeaker, along with a number of other parameters.

Armed with that information, we are able to “know” how those parameters behave with respect to the characteristics of the music that is being played (e.g. how loud it is, in various frequency bands, for how long, in both the short term and the long term). This means that, when you play music on the loudspeaker, it “knows” the following:

- how hot it is at various locations inside,
- the loudspeaker drivers' excursions,
- amplifier demands,
- power supply demands,
- and so on. (The actual list varies according to product – these are just some typical examples...)

So, when some parameter gets close to a maximum (e.g. the amplifier starts to get too hot, or the woofer is nearing maximum allowable excursion) then *something* will be pulled back.

What is pulled back? It depends on the product and the conditions at the time you're playing the music. It could be a band of frequencies in the bass region, it could be the level of the woofer. In a worst-case-last-ditch situation, the loudspeaker might even be required to shut itself down to protect itself from you (or the guests attending your party). Of course, there is no

guarantee that you cannot destroy the loudspeaker somehow – but we do our best to build in enough protection to cover as many conditions as we can.

How is it pulled back (i.e. how quickly and by how much)? That also depends on the product and some decisions we made during the sound design process, as well as what kind of state-of-emergency your loudspeaker is in (some people are very mean to loudspeakers...).

Note that all this is done based on the signals that the loudspeaker is being asked to produce. So it doesn't know whether you've turned up the bass or the volume – it just knows you're asking it to play this signal right now

and what the implications of that demand are on the current conditions (voice coil temperature, for example) This is similar to the fact that the seat belts in my car don't know why the car is stopping quickly – maybe it's because I hit the brakes, maybe it's because I hit a concrete wall – the seat belts just lock up when they're asked to move too quickly. Your woofer's voice coil doesn't know the difference between Eminem and Stravinsky with a bass boost – it just knows it's hot and it doesn't want to get hotter.

19.2 ABL and Beolab 90

In spite of Beolab 90's massive power reserves and four capable woofers, it

still benefits from the inclusion of ABL in its processing. This is due to the fact that the Beolab 90's sound design resulted in a frequency range that extends to approximately 10 Hz. Playing at high listening levels, such a low frequency extension would result in over-excursion of the woofers if ABL were not included in the loudspeaker's processing. However, it should be said that whereas a typical Bang & Olufsen loudspeaker will have an ABL operating at frequency bands from approximately 100 Hz and down, the Beolab 90's ABL only operates below approximately 20 Hz.

Appendix 7: Thermal Compression Compensation

20.1 Introduction

When you read a magazine review of a loudspeaker, it will include a measurement of its “frequency response” (more accurately called its “magnitude response”) which shows (ignoring many things) how loud different frequencies are when they come out of the loudspeaker assuming that they all came in at the same level. Unfortunately, this is only a small part of the truth.

Put a woofer in an appropriately-sized cabinet, connect it to an amplifier. Set the room temperature to 20°C. When everything in the room is the same temperature, measure the woofer’s on-axis magnitude response.

Turn up the room temperature to 100°C. When everything in the room is the same temperature again, measure the woofer’s magnitude response once more.

You will notice that these two measurements look very different - but why?

We can explain a loudspeaker driver’s electromechanical characteristics by breaking it down into different components (both actual and analogical). For example, the suspension (which is comprised of the surround and the spider) can be thought of as a spring. The electrical analogy for this is a capacitor. If you take all of the moving parts in the loudspeaker driver, they all add up to a mass that has to be moved - the electrical analogy for that mass is an inductor (since an inductor has some electrical “inertia”). Some of the components are not an electrical analogy - they are real electrical components. For example, the voice coil, since it’s a coil, acts as an inductor. Since it is a thin bit of wire, it also has some resistance to the flow of electrical current through it, so it’s also a resistor. A simplified version of this breakdown is shown in Figure 20.1.

This shows the components of a moving coil dynamic loudspeaker as a very simplified “circuit” . If these components don’t look familiar to you, don’t worry, it’s not that important for now. Some components in the circuit are actual electrical parts but others are analogies; electrical representations for a mechanical component in the system.

If you know how each of these components behaves, and you know the correct values to put in for a given loudspeaker, and you know how to do the right math, then you can come close to getting a prediction of the response of the loudspeaker that you’re modelling with the circuit. However, if you just put in one value for each component, then you’re assuming that they never change - in other words that you’re dealing with a “linear” system.

The problem is that this assumption is incorrect. For example, the voice coil resistance (the amount that the wire in the voice coil resists the flow of current through it when the loudspeaker driver is not moving) changes with temperature. The hotter the wire gets, the higher the resistance goes. This is a normal behaviour for most resistors. If the voice coil resistance changes, then the whole system behaves differently, since it isn’t the only component in the circuit. So, as we change the temperature of the voice coil, the total response of the loudspeaker changes.

Sadly, the temperature of the voice coil isn’t only dependent on the room temperature as it seemed to be in the beginning of this discussion. As soon as you start playing sound using the loudspeaker, it starts heating up. The louder the signal, the hotter it gets. So as you play music, it heats and cools. The speed with which it heats up and cools down is dependent on its “thermal time constant” - a big woofer with a large voice coil and magnet will take longer to heat up and cool down

(and therefore have a longer thermal time constant) than a small tweeter.

This raises at least four questions:

- How much does the temperature vary when I play music?
- How does the response of the loudspeaker change with temperature?
- How much does the response of the loudspeaker change with temperature?
- What can we do about it?

20.2 Voice coil temperature

A typical loudspeaker driver is, give or take, about 1% efficient. This means that approximately 1% of the power you push into the loudspeaker from the amplifier is converted into sound. The remaining 99% is lost as heat: almost all of it at the voice coil of the loudspeaker. So, the louder your music, the hotter your voice coil gets. Of course, if you have a way of cooling it (for example, by using other parts of the loudspeaker as a radiator to your listening room) then it won’t get as hot, and it will cool down faster.

For example, play pop music that has been mastered at a high level and play it at maximum volume on a Beolab 90 whilst monitoring the temperature of the voice coils. What you’ll see if you do this is something like the Figure 20.2.

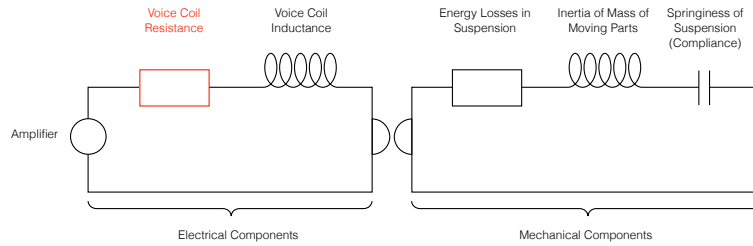

Figure 20.1: A simplified version of the actual electrical and electrical analogies of mechanical components in a loudspeaker driver.

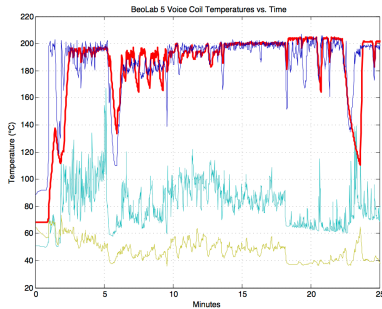

Figure 20.2: The temperatures (in °C) of the voice coils of the drivers in a multi-way loudspeaker as a result of playing pop music at full volume. The X-axis is the time in minutes.

As you can see in Figure 20.2, while playing music, the woofer varied from a maximum temperature of about 200°C down to about 110°C.

This means that the worst-case variation in temperature of the woofer was about 90°C whilst playing music, and peaked at about 180°C above room temperature (which we'll assume is 20°C).

Unfortunately, this temperature cannot be measured directly, since we cannot put thermal sensors directly on the drivers' voice coils. Instead, we measure the temperature of the loudspeaker driver magnets, and use that real-time data input in addition to the signal that we're sending to the drivers to calculate the temperatures of the voice coils based on thermal models of each of them. As you can see in Figure 20.3, the magnet temperature reacts much more slowly. These measurements were taken at exactly the same time as the ones shown in Figure 20.2.

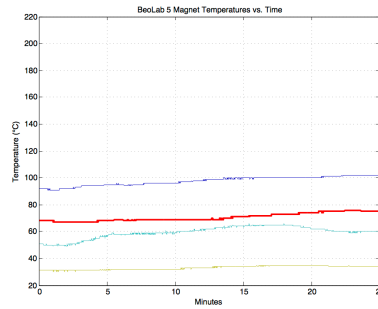

Figure 20.3: The temperatures of the magnets of the drivers in the same loudspeaker as a result of playing pop music at full volume. The X-axis is the time in minutes.

20.3 Loudspeaker response changes

So, now the question is “what does this change in temperature do to the response of the loudspeaker driver?”.

As I mentioned above, the thing that changes most in the model shown in Figure 20.1 is the loudspeaker driver's voice coil resistance. For those of you with a background in reading electrical circuits, you may notice that the one shown in Figure 20.1 has some reactive components in it which will result in a resonance at some frequency. For those of you without a background in reading electrical circuits, what this means is that a loudspeaker driver (like a woofer) has some frequency at which it “wants” to ring – if you thump it with your thumb, that's the note that you will hear ringing – a little like a bell with a low pitch.

As the voice coil resistance goes up, its resistance increases, and we generally lose sensitivity (i.e. level or loudness) from the woofer. In other words, the hotter it gets, the quieter it gets.

However, this only happens at the frequencies where the resistor is not “overridden” by another component; for example, the mechanical resonance of the woofer or the inductance of the voice coil.

The total result is shown for various temperature differences in Figure 20.4. Notice that these plots show the change in magnitude response of the driver with changes in temperature. So, the curve at the top is the change in the woofer's magnitude response (which is 0 dB at all frequencies – in other words no change) when the loudspeaker is playing at the same temperature at which it was measured (let's say, 20°C or room temperature). As the temperature of the voice coil increases above that temperature, you can see that you lose output in two frequency bands on either side of a “bump” in the response – that bump is at the resonant frequency of the loudspeaker driver.

So, the louder you play, the more low end you lose, apart from a peak in the response (which also rings in time) at the resonant frequency of the driver.

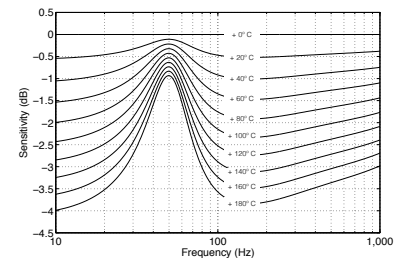

Figure 20.4: Sensitivity of a woofer vs. the change in temperature of its voice coil.

20.4 The solution

Interestingly, everything I said above is true for every moving coil loudspeaker. So, if you're the kind of person who believes that the only "proper" loudspeaker is one where you have nothing but a loudspeaker driver (in a cabinet of any kind, or not) and an amplifier - and no active filtering, then you'll have to live with the kind of unpredictable behaviour that you see above. However, since a Beolab 90 "knows" the temperature of the voice coil of its loudspeaker drivers, and since it has been programmed with the curves like the one shown in Figure 20.4, we can actively linearise its response, making it much more predictable.

In essence all we need to do is to take Figure 20.4, flip it upside down and make a filter that "undoes" the effect of temperature on the loudspeaker's response. For example, if the woofer's voice coil gets 160°C above room temperature (where we originally measured it), it drops 3.2 dB at 20 Hz, the processor knows this and adds 3.2 dB at 20 Hz. In order to do this, the processing of the Beolab 90 includes a set of filters (one for each driver) whose response varies in time with the temperatures of the the drivers. The temperature-dependent filters for the front woofer are shown in Figure 20.5.

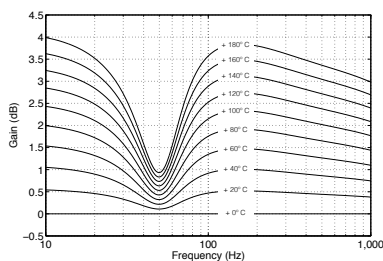

Figure 20.5: Magnitude responses of the compensating filter for a woofer vs. the temperature of its voice coil.

It's important to note three things here.

- This can only be done because we know how the response of the woofer changes at different temperatures (this behaviour was found as part of the development process).
- This can be done because the loudspeaker "brain" (the DSP) knows the temperature of the voice coil in real time as you're playing music
- This particular filter shown in Figure 20.5 should only be applied to the appropriate loudspeaker driver. The other woofers and the other drivers have different behaviours and should be processed with their own correction curves. In other words, this filtering can only be done because the Beolab 90 is an active loudspeaker with independent filtering for each of the 18 loudspeaker drivers.

20.5 Some extra information

You should be left with at least one question. I said above that, as the music gets loud, the woofer heats up, so you lose output, so we add a filter that compensates by putting more signal into the driver. However, this means that the problem is caused by the signal being too loud, and the result is that we make the signal louder.

However, there is one more trick up our sleeve. [Appendix 6: ABL - Adaptive Bass Linearisation](#) describes Beolab 90's Thermal Protection algorithm. This means that the DSP brain knows the temperature of the drivers and, in a worst-case situation, turns the levels down to protect things from burning

up. So, if we go back to the example of a Beolab 90 playing at full volume, let's see what's happening to the signal levels.

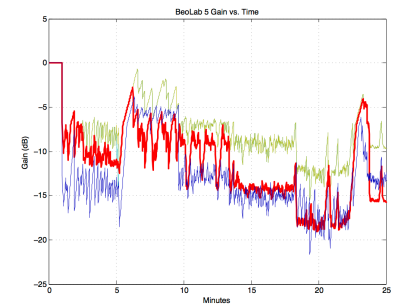

Figure 20.6: The gains (in dB) applied to the signals sent to the drivers in a loudspeaker as a result of playing pop music at full volume. The X-axis is the time in minutes.

These curves in Figure 20.6 show the gains applied to the the drivers in a Beolab loudspeaker at the same time as the measurements shown in Figures 20.2 and 20.3 were being made. In fact, if you look carefully at Figure 20.2 around the 5 minute mark, you'll see that the temperature dropped - which is why the gain in Figure 20.6 increases (because it can!) in response.

Now, don't panic. The Beolab 90 isn't messing about with the gains of the drivers all the time. Remember that this example was done at *full volume* - which, for a Beolab 90 is *extremely loud*. The gains shown in Figure 20.6 are a "last-ditch" effort of the loudspeaker to protect itself from a very mean customer (or the very mean children of a customer who is away for the weekend). This is the equivalent of the airbags deploying in your car. You can guess that, if the airbag is outside the steering wheel something significant has occurred.

Many thanks to Gert Munch for his help in writing this section.

Appendix 8: Control of Beolab 90 using the BeoRemote 1

21.1 Introduction

The BeoRemote 1 can be used instead of the smartphone interface to control a number of parameters on the Beolab 90. The usage and setup of these are described below

Note that, in order to control the Beolab 90s with the BeoRemote 1, two things must initially be configured. Firstly, the infra-red receiver (also known as an "IR Eye") must be correctly connected to the Primary Beolab 90. Secondly, the BeoRemote 1 must be set to the "BeoSound" product on its display.

21.1.1 Customising the Product Name

It is possible to customise the product name displayed on the BeoRemote 1 (for example, to read "Beolab 90" instead of "BeoSound"). This can be done as follows:

1. Press LIST
2. Scroll down to SETTINGS and press the round GO button
3. Scroll down to ADVANCED and press GO
4. Select PRODUCTS and press GO
5. Select RENAME and press GO
6. Select the item you wish to rename and press GO
7. "Type" in the new name for the item
8. When you are done, scroll all the way to the right of the list of letters and select the CHECK MARK to store.

21.2 Input Selection

It is possible to manually change the input selection of audio sources using the BeoRemote 1. In addition, the display of the remote control can be customised to reflect your particular setup.

21.2.1 Source Selection

If you press the MUSIC button on the remote, you will see a number of sources listed there that are scrollable using the UP/DOWN buttons, and selectable using the GO button on the remote control. Firstly, you will need to customise this list as follows:

1. press LIST
2. Scroll down to SETTINGS and press GO
3. Scroll down to MUSIC sources and press GO
4. Select SHOW and press GO
5. Use the GO button to place a check mark next to the following items in the following list. (It may also be helpful to remove the check marks next to the items that are not in the list.)
 - NET RADIO
 - MUSIC
 - LINE IN
 - CD
 - A.MEM

Now press the MUSIC button and you should see these 5 items in a scrollable list on the screen of the remote. These 5 are mapped to the inputs of the Beolab 90 as follows:

BL90 Input BR1 Display

| | |
|-----------|-----------|
| Automatic | Music |
| RCA | Line-In |
| XLR | A.Mem |
| S/PDIF | CD |
| Optical | NET Radio |

So, for example, if the Beolab 90 is in Automatic mode and you playing signals on both the S/PDIF and the XLR inputs simultaneously, you will hear the S/PDIF signal if it has a higher selection priority. Press MUSIC and select A.MEM to switch manually to the XLR input. Press MUSIC and select CD to switch to the S/PDIF input.

21.2.2 Customising the Input Names

It is possible to re-name these inputs on the BeoRemote 1's display so that you do not have to remember the mapping. This can be done as follows:

1. Press LIST
2. Scroll down to SETTINGS and press GO
3. Scroll down to MUSIC sources and press GO
4. Select RENAME and press GO
5. Select the item you wish to rename and press GO
6. "Type" in the new name for the item
7. When you are done, scroll all the way to the right of the list of letters and select the CHECK MARK to store.

Now, when you press the MUSIC button, you will see the labels you have entered instead of the default ones listed above.

Index

- ABL, 32, 57
- active listening, 8
- active room compensation, 10, 21
- Adaptive Bass Linearisation, 57
- ADC, 34
- analogue-to-digital converter, 34
- ARC, 10, 21, 55
- audio formats
 - DoP, 39, 41, 42
 - DSD, 39
 - DSD over PCM, 41, 42
 - DXD, 41, 42
- automatic bass linearisation, 32
- background music, 8
- bass, 23
- beam direction, 9
- beam direction control, 19
- beam width
 - control, 9, 16
 - narrow, 16
 - omni, 18
 - wide, 17, 19
- BeoRemote 1, 62
- Beovision television, connection to, 26
- centre frequency, 47
- cloning in production, 33
- coaxial digital (S/PDIF), 36
- converter, digital to analogue, 36
- DAC, 36
- dB, 47
- decibel, 47
- digital signal processor, 36
- digital to analogue converter, 36
- distance, 20
- DSP, 36
- early reflections, 49
- echo, 41
- edit mode, menu, 15
- equaliser, parametric, 24, 31
- Fc, 47
- features, 32
- features disabled, 41
- filter
 - high-shelving, 25, 46
 - low-shelving, 24, 46
 - peaking, 25, 47
 - phase response, 32
 - Q, 47
 - reciprocal peak/dip, 47
- formats
 - DXD, 39
- gain, 47
 - equaliser, 47
 - filter, 47
- Hertz, 47
- high-shelving filter, 25, 46
- Hz, 47
- imaging, 8, 16
- impedance, input, 29
- input
 - detection threshold, 28
 - impedance, 29
 - maximum input voltage, 28
 - time-out, 29
- input selection
 - manual, 28
 - priority, 28
- inputs
 - analogue, 34
 - digital, 35
- IP Address, 7, 12, 13
- latency, 23
- level, 20
- Listening Mode, 11
- low-shelving filter, 24, 46
- maximum input voltage, 28
- menu map, 14
- microphone placement, 55
- minimum phase, 24
- modes, room, 51
- mute, 22
- optical digital, 36
- parametric equaliser, 24, 31
- passive listening, 8
- peaking filter, 25, 47
- phantom imaging, 16
- Power Link, 35
- preset, 15
 - by source, 28
 - creating, 15
 - edit parameters, 15
 - selecting, 15
- preset automation, 26
- Primary, 21
- production, 33
- protection, thermal, 32
- Q, 47

- RCA, 35
- reciprocal peak/dip filter, 47
- reflections, early, 49
- reverberation, 52
- role, 21
- room modes, 51

- S/PDIF, 36
- sampling rate converter, 35
- Secondary, 21
- sensitivity, 20, 22, 31
- signal detection, automatic, 28
- software version, 12
- sound design, 32
- speaker distance, 20
- speaker group, 26
- speaker level, 20
- Speaker Preset, 26
- speaker role, 21
- specifications, technical, 34
- SRC, 35

- stereo imaging, 8, 16

- technical specifications, 34
- thermal compression compensation, 33, 59
- thermal protection, 32
- threshold, detection, 28
- time-out, 29
- treble, 23

- USB Audio, 36

- volume
 - control, 22, 31
 - maximum, 30
 - startup, 22, 30

- Wireless Power Link, 36
- WiSA, 36
- WPL, 36

- XLR, 35